

Inhaltsverzeichnis:

Standard-Typen von Wellendichtringen

Technische Daten:

- Beschreibung der Radialwellendichtringe
- Funktionsprinzip
- Metallgehäuse
- Zugfeder
- Elastomere Dichtungswerkstoffe

Einbau und Betrieb:

- Welle
- Gehäusebohrung
- Schmierung
- Temperatur
- Druck

Herstellung und Qualitätssicherung:

- Presssitzzugabe und zulässige Unrundheit des Außendurchmessers
- Endkontrolle

Dina- Dichtung (HW 500)

Lagerung und Handhabung

Abmessungstabelle

Bestellbeispiel

Der Wellendichtring ist eine unverzichtbare Komponente zur Abdichtung von drehenden Wellen in vielen Anwendungsbereichen des Maschinenbaus. Die sorgfältige Auswahl sowohl der Form als auch des Werkstoffes gewährleistet die sichere Funktion und hohe Standzeiten des Bauteiles.

Besondere Merkmale:







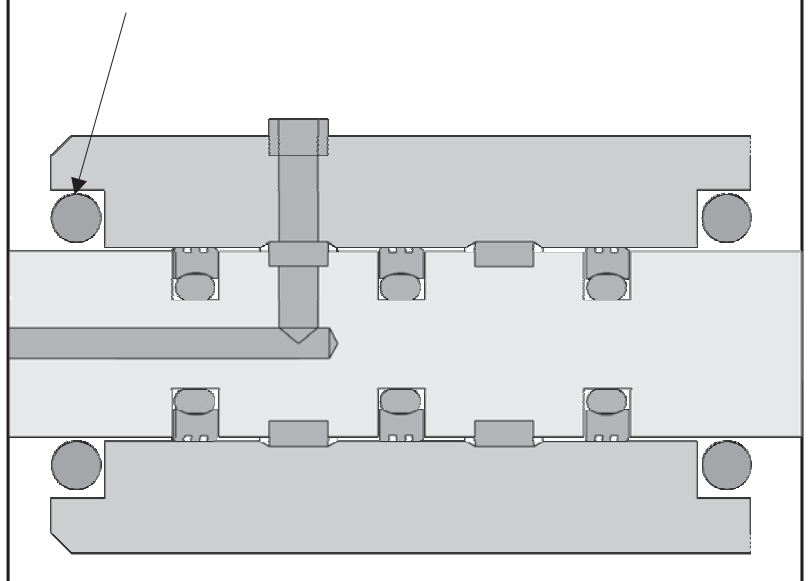



- Gutes Verschleißverhalten, niedrige Reibung
- Kleine, einfach herzustellende Einbauräume
- Große Auswahl an Abmessungen und Formen
- Hohe Rotationsgeschwindigkeiten möglich
- Viele Abmessungen auch in FPM und Silikon lieferbar
- Für spezielle Anwendungen Feder auch in Niro-Stahl erhältlich



Werkstoff	: Gummielastomer/Metall-Verbindung
Betriebsdruck	: bis 0,8 Mpa (8 bar) (abhängig von der Bauform)
Geschwindigkeit	: rotierend bis 38 m/s (abhängig vom Werkstoff)
Temperatur	: -60° C bis +220° C (abhängig vom Werkstoff)



1. Standard-Typen von Wellendichtringen (nach DIN 3760)

HW 400		A (HW400)	Umvulkanisierter Metallkäfig Dichtlippe mit Zugfeder
HW 410		AS (HW410)	Umvulkanisierter Metallkäfig Dichtlippe mit Zugfeder und zusätzlicher Staublippe
HW 420		C (HW420)	Metallisches Gehäuse mit Versteifungskappe Dichtlippe mit Zugfeder
HW 430		CS (HW430)	Metallisches Gehäuse mit Versteifungskappe Dichtlippe mit Zugfeder und zusätzlicher Staublippe
HW 440		B (HW440)	Metallisches Gehäuse Dichtlippe mit Zugfeder
HW 450		BS (HW450)	Metallisches Gehäuse Dichtlippe mit Zugfeder und zusätzlicher Staublippe
Weitere Typen:			
HW 460		P (HW460)	Umvulkanisierter Metallkäfig, verstärkte Dichtlippe für Überdruck und zusätzlicher Staublippe
HW 470		O (HW470)	Umvulkanisierter Metallkäfig Dichtlippe ohne Zugfeder
HW 480		DUO (HW480)	Umvulkanisierter Metallkäfig Zwillingsdichtlippe mit zwei Zugfedern
HW 500		DINA (HW500)	Radialabstreifer / Wellendichtring ohne Zugfeder

Für spezielle Anwendungen können Radialwellendichtringe auch mit hydrodynamischem Rechtsdrall, mit hydrodynamischem Linksdrall oder hydrodynamischem Wechseldrall an der Dichtlippe geliefert werden. Bitte fragen Sie im Bedarfsfall an.

2. Technische Daten

2.1. Beschreibung der Rotationswellendichtung

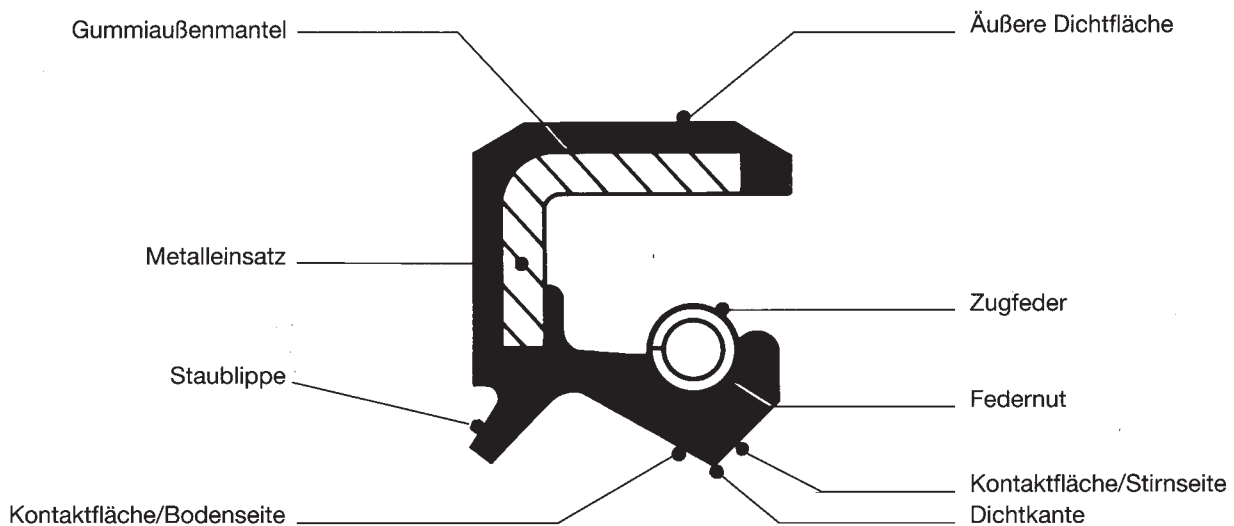

2.2 Funktionsprinzip

Der Raum zwischen der Dichtlippe und der Welle ist von größter Bedeutung. Der Dichteffekt wird erzielt durch die Vorspannung der Dichtlippe, d.h. indem man ihren Innendurchmesser ein wenig kleiner wählt als den Wellendurchmesser. Die Zugfeder sorgt für konstanten Druck und erhält den radialen Druck auf die Welle, wodurch die Dichtkante auf eine definierte Breite abgeflacht wird. Unter diesem abgeflachten Bereich bildet sich ein dünner Flüssigkeitsfilm. Dieser muß 1 bis 3 µm dick sein, um Leckage zu verhindern. Der Schmierfilm wirkt als Schnittstelle zwischen der Außenluft und der Flüssigkeit. Ein Riß im Schmierfilm führt zu Undichtigkeit. Dies kann geschehen, wenn die Welle Kratzer in der Dichtfläche aufweist.

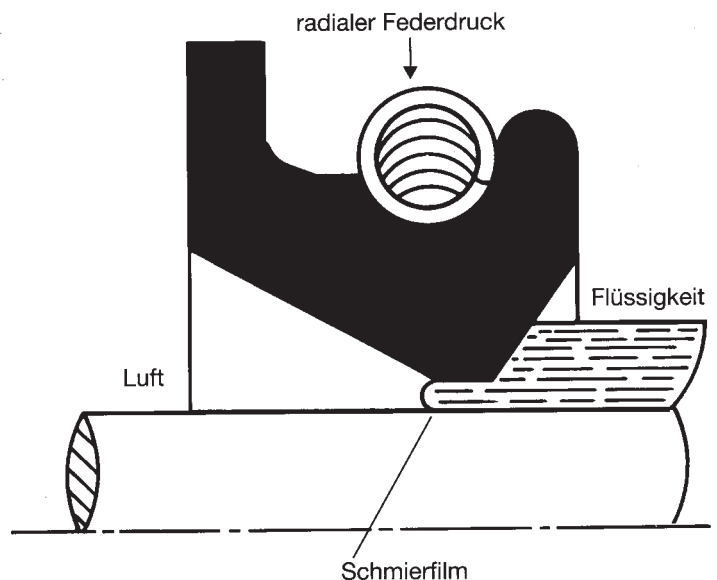

2.3. Metallgehäuse

Der Metalleinsatz oder das Gehäuse wird verwendet, um der Dichtung Stabilität und Festigkeit zu geben. Üblicherweise besteht es aus kalt gerolltem Stahl nach DIN 1624.

Um Rost oder chemische Angriffe zu vermeiden, kann rostfreier Stahl verwendet werden.

- Chrom-Nickel AISI 304 (DIN 1.4301 - V2A)
- Chrom-Nickel-Molybdän AISI 316 TI (DIN 1.4401 - V4A)

2.4. Zugfeder

Die Zugfeder erhält die radiale Kraft, die von der Dichtlippe auf die Wellenoberfläche ausgeübt wird. Sie wird üblicherweise aus harmonischem Federstahldraht C 72 oder aus rostfreiem Stahldraht Chrom-Nickel AISI 302 (DIN 1.4300) gefertigt.

Für spezielle Anwendungsfälle sind auch Federn in rostfreiem Stahl AISI 316 TI (DIN 1.401 - V4A) erhältlich.

Alle unsere Standard-Wellendichtringe, welche aus dem Werkstoff FPM (Viton) hergestellt werden, sind mit rostfreien Stahlfedern in AISI 302 ausgestattet.

2.5. Elastomere Dichtungswerkstoffe

2.5.1 Nitrilkautschuk NBR (HME-Werkstoff-Nr. 100)

Dieses Elastomer ist ein Co-Polymer von Butadien und Acrylnitril und wird für die Mehrzahl der herkömmlichen Anwendungsfälle eingesetzt.

Physikalische Daten:

- Betriebstemperatur : -40 °C bis +120 °C / +90 °C in Wasser
- Zugfestigkeit: bis 15 Mpa
- Standardfarbe: schwarz

Vorteile:

- Gute Beständigkeit gegen Mineralöl und Schmierfett
- Gute Beständigkeit gegen Wasser und Kühlflüssigkeit
- Hohe Reißfestigkeit

Einschränkungen:

- Geringe Beständigkeit gegen stark vermisches Hypoid-Öl
- Geringe Beständigkeit gegen Sauerstoff, Witterungseinflüsse und Sonnenlicht
- Geringe Beständigkeit gegen polare Flüssigkeiten (Ketone, Äther, Ester)
- Geringe Beständigkeit gegen chlorierte Kohlenwasserstoffe (Karbon-Tetrachlorid, Trichlorethylen)
- Geringe Beständigkeit gegen aromatische Lösungsmittel
- Keine Beständigkeit gegen Kfz-Bremsflüssigkeiten (auf Glykol-Basis)

2.5.2 Fluorkautschuk FPM (HME-Werkstoff-Nr. 120)

Hauptsächlich bekannt unter dem Handelsnamen VITON von DuPont, TECHNOFLON von Montedison und FLUOREL von 3M. Es besitzt gute chemische Beständigkeit und wird für Anwendungsfälle mit hohen Temperaturen empfohlen.

Physikalische Daten:

- Betriebstemperatur: -30 °C bis +200 °C
- Zugfestigkeit: bis 15 Mpa
- Standardfarbe: braun

Vorteile:

- Hervorragende Beständigkeit gegen Mineralöl und, vor allem, gegen stark vermischte Hypoid-Öle
- Hervorragende Säurebeständigkeit

- Hervorragende Beständigkeit gegen aromatische und chlorierte Kohlenwasserstoffe
- Hervorragende Beständigkeit gegen Alterung, Sauerstoff und Witterung.

Einschränkungen:

- Beschränkte Kälteflexibilität
- Geringe Beständigkeit gegen polare Flüssigkeiten (Ketone, Äther, Ester)

2.5.3 Silikonkautschuk SIL (HME-Werkstoff-Nr. 180)

Auch bekannt als MVQ

Physikalische Daten:

- Betriebstemperatur: -60 °C bis +220 °C
- Zugfestigkeit: ca. 3-7 Mpa
- Standardfarbe: rot

Vorteile:

- Behält Flexibilität bis zu sehr tiefen Temperaturen
- Widersteht ständiger Erhitzung bei sehr hohen Temperaturen ohne zu verhärten
- Beständigkeit gegen Mineralöl und Schmierfette
- Hervorragende Beständigkeit gegen Alterung, Witterungseinflüsse und Sauerstoff
- Gute chemische Beständigkeit gegen Alkale

Einschränkungen:

- Nicht empfohlen für den Einsatz mit Kohlenwasserstoffen wie Kraftstoffen und Paraffin, sowie leichten Mineralölen und Dampf über 3,5 bar
- Nicht beständig gegen heißes Wasser, Säuren und nichtmineralischen Kfz-Bremsflüssigkeiten
- Geringe Verschleißbeständigkeit

3. Einbau und Inbetriebnahme

3.1. Welle

Die Beschaffenheit der Wellenoberfläche ist von äußerster Bedeutung für wirkungsvolles Abdichten und für eine lange Lebensdauer.

Grundsätzlich sollte die Oberflächenhärte der Lauffläche mit zunehmender Umfangsgeschwindigkeit der Welle steigen. Nach DIN 3760 beträgt die erforderliche Mindesthärte 45 HRC. Bei einer Umfangsgeschwindigkeit von 4 m/s sollte die Härte 55 HRC betragen, bei 10 m/s 60 HRC.

Die Schmierung ist ebenfalls sehr wichtig. Siehe Absatz 3.3 .

Die Oberflächenbeschaffenheit, wie sie durch DIN 3760 spezifiziert ist, muss $R_a = 1-4 \mu\text{m}$ sein. Rauhere Oberflächen führen zu höherer Reibung und verursachen höhere Temperaturen. Fabrikationsfehler und Kratzer auf der Welle müssen vermieden werden.

Schon sehr kleine Defekte können genügen, um die Schmierfilmdicke zu erhöhen, möglicherweise den Schmierfilm zu unterbrechen und zur Leckage zu führen. Ebenso wichtig ist es, spiralförmige Oberflächen oder parallele Kerben zu vermeiden, da diese einen Pumpeffekt und Undichtigkeit verursachen können.

Der meistverwendete Werkstoff für Wellen ist gehärteter Stahl. Die Fertigungstoleranz ist h11, in Übereinstimmung mit der ISO Standard UNI-6388-68 (siehe unten stehende Tabelle).

Wellendurchmesser		Toleranz
von (mm)	bis (mm)	h11
6	10	0,000 - 0,090
10	18	0,000 - 0,110
18	30	0,000 - 0,130
30	50	0,000 - 0,160
50	80	0,000 - 0,190

Wellendurchmesser		Toleranz
von (mm)	bis (mm)	h11
80	120	0,000 - 0,220
120	180	0,000 - 0,250
180	250	0,000 - 0,290
250	315	0,000 - 0,320
315	400	0,000 - 0,360

Die günstigste Einsatzbedingung ist gegeben, wenn sich die Welle perfekt zentriert und konzentrisch zur Achse der Radialwellendichtung dreht. Natürlich ist das meist nicht möglich und eine gewisse Rundlaufabweichung ist unvermeidbar. Diese sollte jedoch möglichst gering gehalten werden, weil insbesondere bei hohen Drehzahlen die Gefahr besteht, dass die Dichtkante infolge ihrer Trägheit der Welle nicht folgen kann. Es ist deshalb zweckmäßig, den Wellendichtring in unmittelbarer Nähe des Lagers anzuordnen und das Lagerspiel so klein wie möglich zu halten.

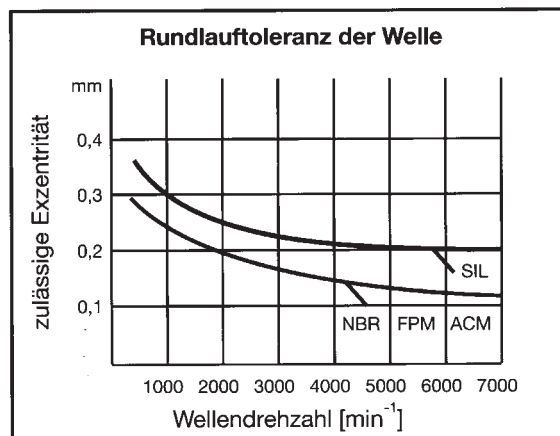

Die Unrundheit zwischen Welle und Gehäusebohrung muß möglichst klein gehalten werden, um einseitige Belastung (Verschleiß) der Dichtlippe weitgehend zu reduzieren.

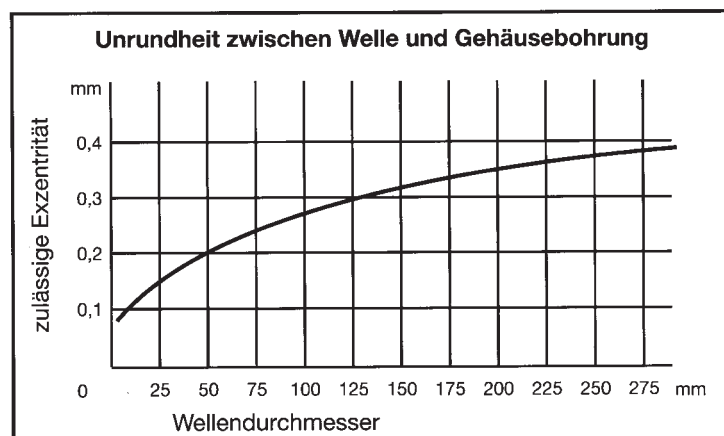

3.2. Gehäusebohrung

Ein guter Preßsitz der Wellendichtung in der Gehäusebohrung ist von entscheidender Bedeutung.

Für den Bohrungsdurchmesser ist in Übereinstimmung mit der ISO Standard UNI-6388-68 (siehe untenstehende Tabelle), das Toleranzfeld H8 vorzusehen.

Bohrungsdurchmesser		Toleranz
von (mm)	bis (mm)	H 8
10	18	+0,027 0,000
18	30	+0,033 0,000
30	50	+0,039 0,000
50	80	+0,046 0,000
80	120	+0,054 0,000

Bohrungsdurchmesser		Toleranz
von (mm)	bis (mm)	H 8
120	180	+0,063 0,000
180	250	+0,072 0,000
250	315	+0,081 0,000
315	400	+0,081 0,000

Die maximale Oberflächenrautiefe der Bohrung beträgt, nach DIN 3760, $R_t = 16 \mu\text{m}$. Wir empfehlen einen Anschlag oder Sicherungsring, gegen welchen die Dichtung fixiert werden kann. Sollte dies nicht möglich sein, muss darauf geachtet werden, dass die Dichtung genau zur Wellenachse fluchtet. Um die Montage zu erleichtern, muss das Gehäuse stirnseitig zwischen 5° und 10° angeschrägt sein, mit einer Tiefe von 1 mm für Ringe bis zu 10 mm Stärke bzw. einer Tiefe von 1,2 - 1,5 mm für Ringe, die dicker sind als 10 mm (siehe Zeichnung unten). Ebenso muss die Welle stirnseitig eine Anschrägung mit einem Winkel von $15^\circ - 25^\circ$ aufweisen, mit gerundetem und poliertem Übergang.

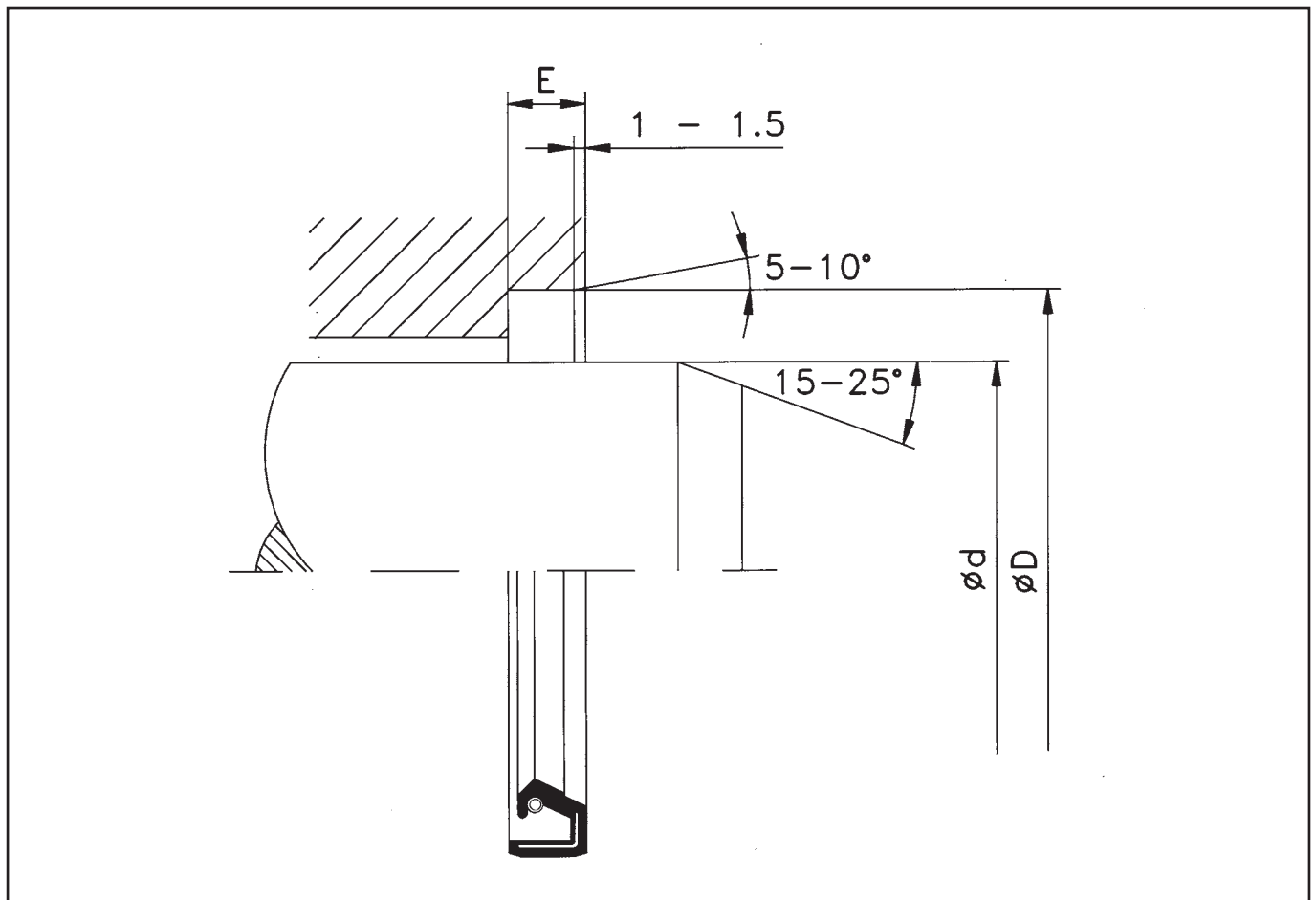

3.3 Schmierung

Die Schmierung ist sehr wichtig für das gute Funktionieren der Dichtung. Die Dichtlippe bewegt sich tatsächlich nicht direkt auf der Wellenoberfläche, sondern auf einem sogenannten Schmierfilm (siehe Kapitel 2.2). Die Dicke des Schmierfilms beträgt üblicherweise 1-3 µm, jedoch unterliegt dieser Wert vielen Faktoren wie Viskosität des Öls, Oberflächenbeschaffenheit der Welle und radiale Vorspannung der Dichtung.

Die ersten paar Betriebsstunden werden „Einbetten“ genannt. Dieser Vorgang ist sehr wichtig, nicht nur, damit sich der Schmierfilm bilden kann, sondern auch für das Abflachen der Dichtkante.

Während dieser Zeit ist eine gewisse Undichtigkeit möglich.

Ein ausreichender Schmierfilm reduziert stark die Reibung zwischen Dichtlippe und Welle und fungiert außerdem als Kühlmittel gegen die entstehende Hitze. Je niedriger die Temperatur gehalten werden kann, desto größer ist die Haltbarkeit der Dichtung. Wenn die Flüssigkeit nur geringe Schmierfähigkeit besitzt (Wasser und wässrige Lösungen), muß eine der Wellendichtungstypen mit Staublippe (AS, BS oder CS) verwendet werden. In diesem Fall sorgen Sie bitte dafür, daß der Raum zwischen den zwei Lippen mit Schmierfett gefüllt wird. Die Reibungshitze hängt des weiteren von der Umfangsgeschwindigkeit der Welle ab.

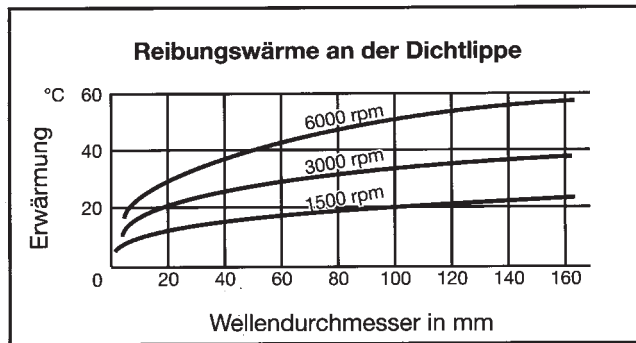

Reibung kann nicht nur das Dichtlippenmaterial schädigen, sondern verursacht auch Reibungsverluste. Dies kann sich relativ stark auswirken, wenn nur geringe Kräfte übertragen werden.

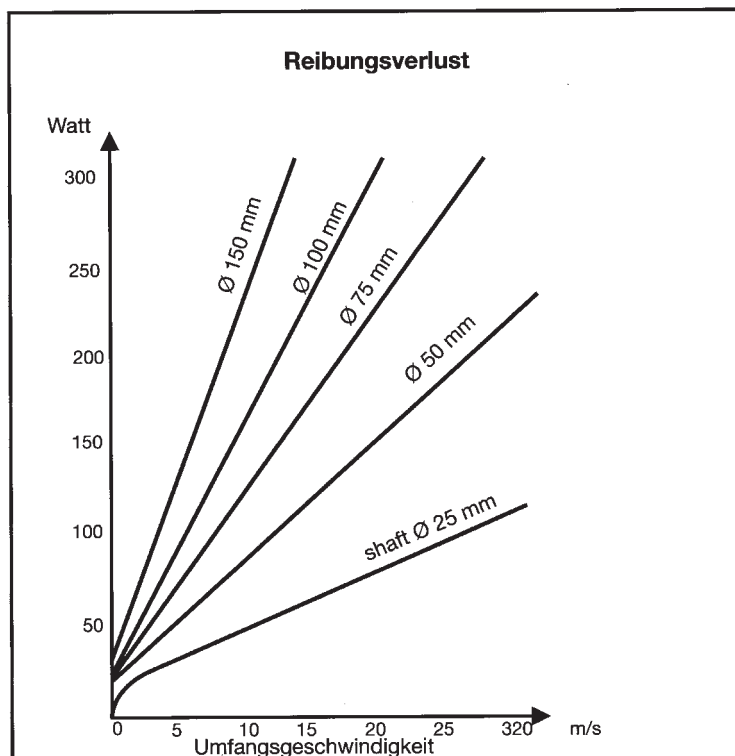

3.4. Temperatur

Die Temperatur an der Dichtlippe entspricht der Medientemperatur, erhöht durch die Reibungshitze.

Je höher die tatsächliche Betriebstemperatur ist, desto schneller verläuft der Alterungsprozess des Elastomers, wodurch auch die Funktion der Dichtlippe und die Wellenoberfläche beeinflusst werden.

Die Reibungshitze hängt ab von Umfangsgeschwindigkeit, Dichtlippenvorspannung, Oberflächenbeschaffenheit der Welle, Schmierung, Medium etc.

Die Abbildung unten zeigt die zulässigen Drehzahlen bezogen auf die unterschiedlichen Werkstoffe (Druckloser Betrieb, gut schmierendes Mineralöl und gute Wärmeabführung).

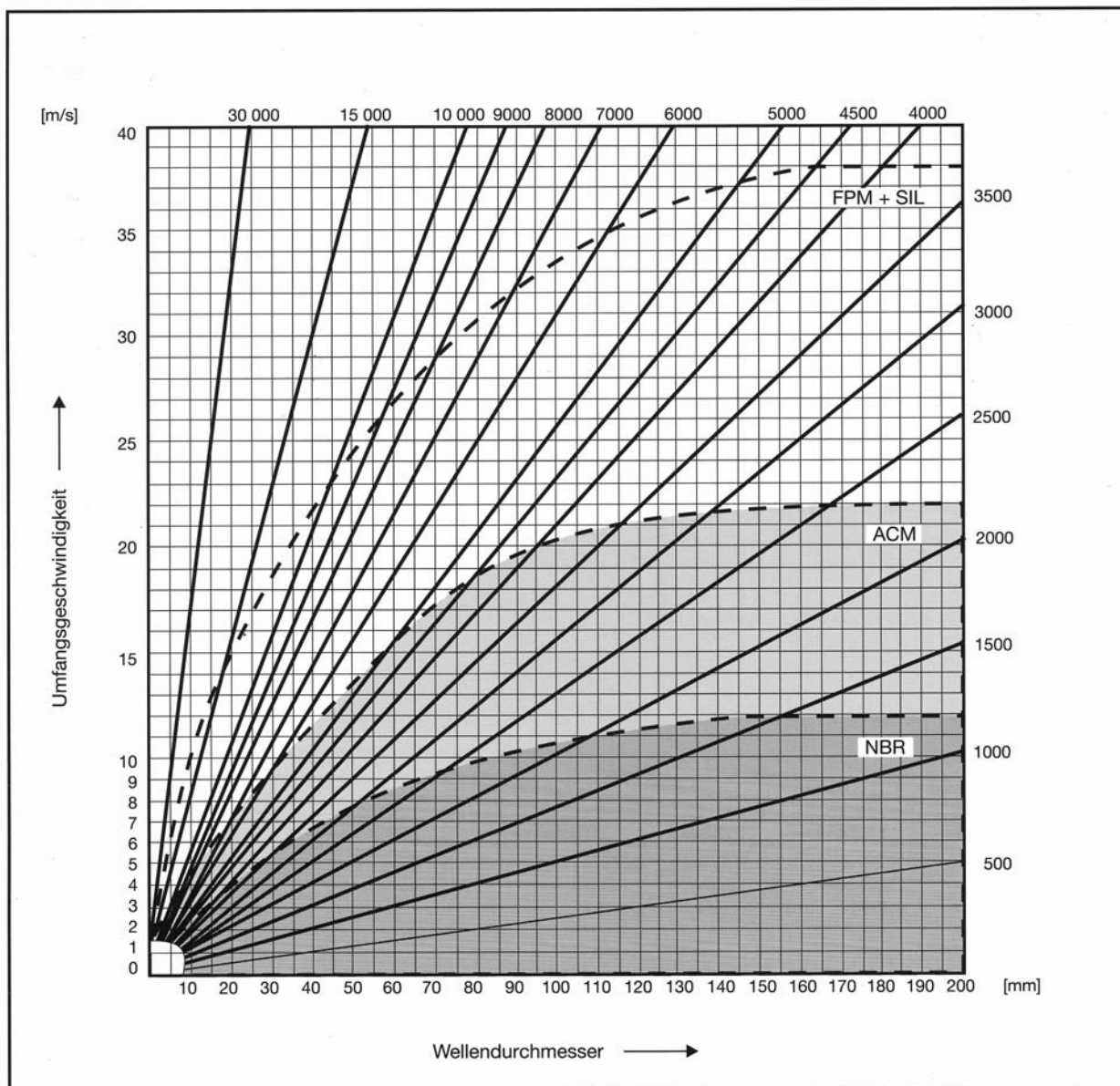

3.5 Druck

In den meisten Anwendungsfällen herrscht kein oder nur ein geringer Differentialdruck. Wo jedoch der Radialwellendichtring einem Druck ausgesetzt ist, wird die Dichtlippe gegen die Welle gedrückt, wodurch die Temperatur erhöht wird. In manchen Fällen kann der Druck sogar zum Umklappen der Dichtlippe führen.

Bei über 0,2 bar mit hohen Drehzahlen oder über 0,5 bar bei niedrigen Drehzahlen müssen Stützringe oder speziell entwickelte Radial-Wellendichtringe mit stärkeren Dichtlippen und unterstützenden Metalleinsätzen verwendet werden. In letzterem Fall weisen wir auf unsere P-Typen (z.B. HW460) hin. Trotzdem sind auch mit Wellendichtungen der Type P die zulässigen Überdrücke begrenzt (siehe Diagramm unten).

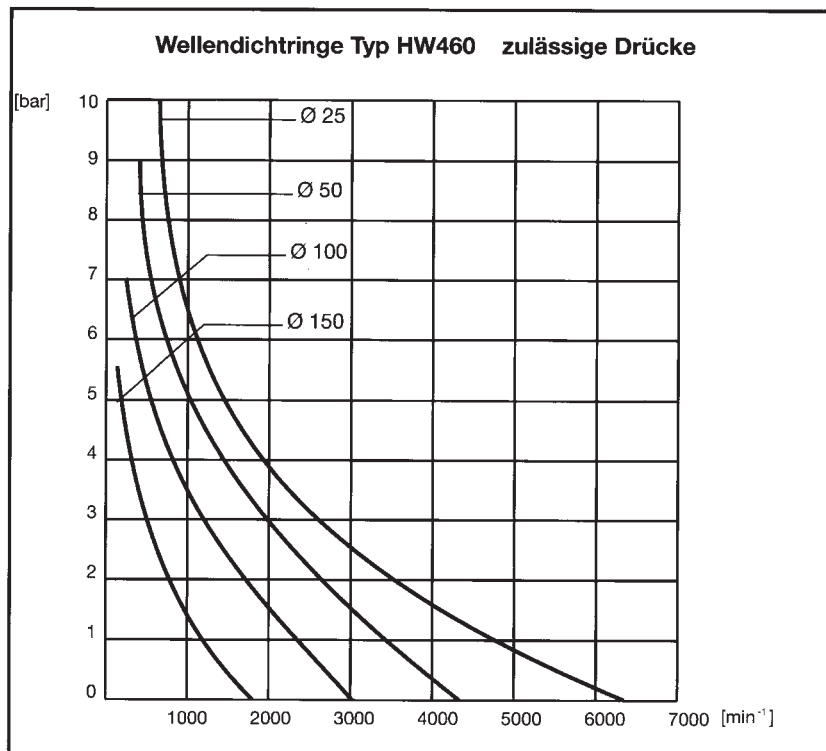

Auf Anfrage können wir Wellendichtringe liefern, die eine speziell verstärkte Dichtlippe haben, so dass diese auch Drücke über dem angegebenen Wert standhalten.

Wenn Stützringe eingebaut werden, können standardmäßige Radial-Wellendichtungen verwendet werden. Allerdings verursachen Stützringe höhere Kosten und oftmals ist der nötige Einbauraum nicht vorhanden. Manchmal ist der Einsatz von Stützringen auch deshalb nicht möglich, weil sie sowohl eine äußerst sorgfältige Montage als auch eine sehr geringe Rundlaufabweichung der Welle erfordern.

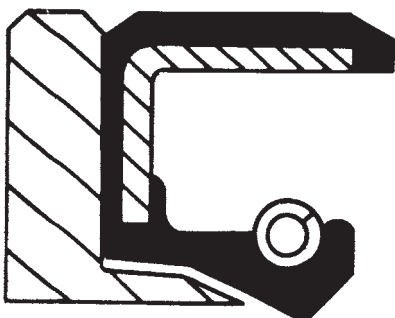

Speziell entwickelte Radialwellendichtungen (P-Typen) sind hier vorzuziehen, selbst wenn eine sorgfältigere Montage und eine geringere Rundlaufabweichung der Welle erforderlich sind als im Normalfall.

4. Herstellung und Qualitätssicherung

Die Radialwellendichtringe aus unserem Programm werden nach Deutschem Standard DIN 3760 und den Qualitätssicherungsstandards ISO 9000 ff. hergestellt.

Alle Produktionsphasen werden überprüft und alle Maßnahmen aufgezeichnet und aufbewahrt, um diese bei Bedarf nachzuvollziehen.

4.1 Preßsitzzugabe und zulässige Unrundheit des Außendurchmessers

Nach Deutschem Standard DIN 3760

Außendurchmesser (mm)	Preßsitzzugabe			zulässige Exzentrizität HW420 - HW460
	HW400	HW410	HW420 - HW460	
- bis 50	+0,30 +0,15		+0,20 +0,10	0,25
über 50 bis 80	+0,35 +0,20		+0,23 +0,13	0,35
über 80 bis 120	+0,35 +0,20		+0,25 +0,15	0,50
über 120 bis 180	+0,45 +0,25		+0,28 +0,20	0,65
über 180 bis 300	+0,45 +0,25		+0,30 +0,20	0,80
über 300 bis 500	+0,55 +0,30		+0,35 +0,23	1,00

4.2 Endkontrolle (Standard)

In Übereinstimmung mit unseren Produktionsstandard und DIN 3761, Teil 4

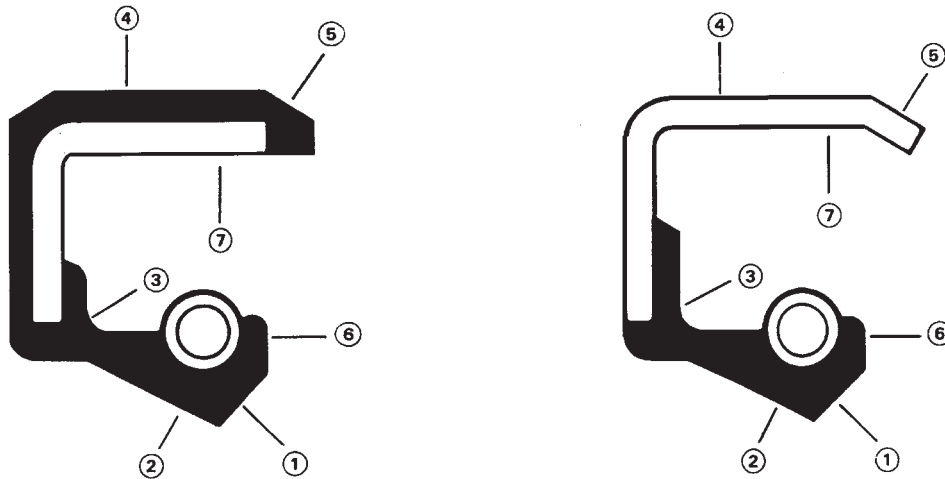

	Bereich	Nicht zulässig	Zulässig
1 + 2	Dichtkante 1 = Stirnseite 2 = Bodenseite	Risse in der Dichtkante	Keine Mängel zulässig
3	Vulkanisierungsradius	Vulkanisierungsmängel	
4	Außendurchmesser der Welle	Fehler, die die Dichtung am Außendurchmesser beeinflussen	Kleinere Mängel, vorausgesetzt, dass mindestens 2/3 des Außendurchmessers an diesem Punkt in Ordnung sind.
5	Einführungsschräge	Fehler, die den Einbau der Dichtung beeinträchtigen	
6	Federrückhaltelippe	Verkürzungen, die einen Spalt verursachen können	Kleine Verkürzungen
7	Innenwand	Lose Späne	Späne, die fest mit der Innenwand verbunden sind

Die Kontaktflächen der Dichtlippe ist, nach DIN 3761, Teil 4 wie folgt definiert:

Wellendurchmesser	Stirnseitenbreite	Bodenseitenbreite
- bis 50 mm	0,5 mm	1,2 mm
51 bis 120 mm	0,8 mm	1,5 mm
über 121 mm	1,0 mm	2,0 mm

5. DINA-Dichtung (HW 500)

Hierbei handelt es sich um eine speziell entwickelte Radialwellendichtung, die bei Anwendungsfällen mit Nadellagern verwendet wird. Die DIN-Dichtung ist mit einem Stahleinsatz verstärkt und hat eine dünne Dichtlippe ohne Feder, welche durch minimale Vorspannung nur geringe Reibungsverluste hat. Um einen besseren Sitz der Bohrung zu garantieren, hat die DINA-Dichtung einen gummibeschichteten Außendurchmesser, (mit Ausnahme der kleinen Dichtungen bis 7 mm Außendurchmesser, welche einen glatten Metall-Außendurchmesser haben).

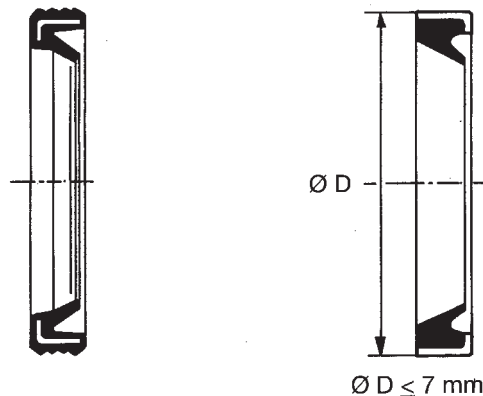

Standardmäßige DINA-Ring-Werkstoffe sind NBR-Elastomer und Karbonstahleinsatz.

Für spezielle Anwendungsfälle sind, auf Anfrage, auch FPM- und Sil-Elastomere und/oder rostfreier Stahleinsatz erhältlich.

Die DINA-Dichtung verhindert Leckage, wenn sie mit der Stirnseite zum Nadellager hin eingebaut wird, oder sie schützt das Lager vor Staub- und Schmutzeintritt, wenn sie mit der Bodenseite zum Lager hin montiert wird.

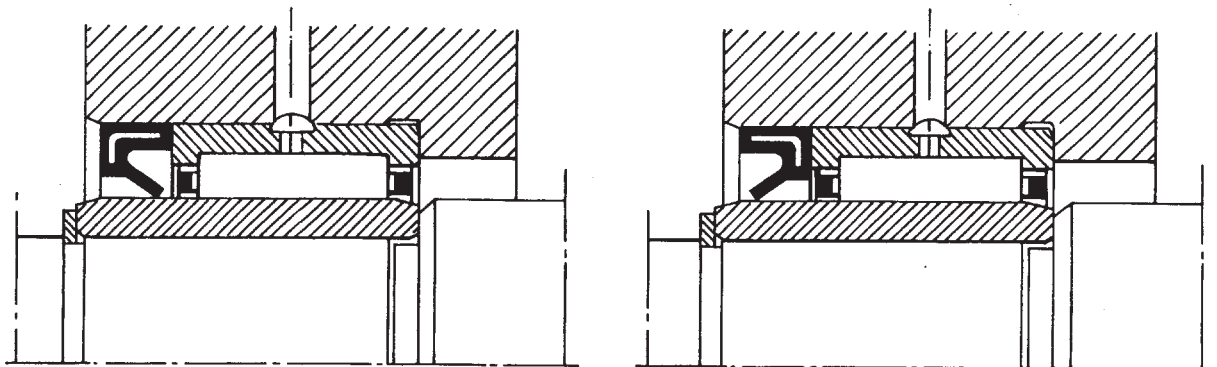

6. Lagerung und Handhabung











Einige Vorsichtsmaßnahmen betreffend der Lagerung müssen beachtet werden um Materialschäden zu vermeiden.











Radial-Wellendichtungen sollten in einer staubfreien und trockenen Umgebung gelagert werden und sie müssen in ihrer Originalverpackung bleiben, welche erst kurz vor der Montage geöffnet werden sollte. Muster sollten nach der Untersuchung wieder verpackt werden. Übermäßige Feuchtigkeit beeinträchtigt einige Elastomere und führt außerdem zu Korrosionsschäden an Metallgehäuse und Feder.











Radial-Wellendichtungen weder auf Regale oder in Schachteln werfen, noch auf Haken, Drähte oder Nägel hängen, da in diesem Fall die Dichtlippe beschädigt werden kann. Dichtungen sollten horizontal gelagert werden.











Ebenso ist es ratsam, Dichtungen nach dem „First-in-First-out“-Prinzip zu lagern, um zu vermeiden, dass sie bereits im Regal altern. Vermeiden Sie Lagerung neben Wärmequellen oder elektrischen Geräten, welche Ozon abgeben können. Vor direktem Sonnenlicht schützen.











7. Abmessungen:











Ø d h11	Ø D H8	E +0,3											Teile-Nr.
			400	410	420	430	440	450	460	470	480	500	
4,00	8,00	2,00										x	HW..... 0040-01-100
4,00	12,00	6,00	x										HW..... 0040-02-100
5,00	9,00	2,00										x	HW..... 0050-01-100
5,00	10,00	2,00										x	HW..... 0050-02-100
5,00	15,00	6,00	x										HW..... 0050-03-100
5,00	16,00	6,00	x										HW..... 0050-04-100
6,00	10,00	2,00										x	HW..... 0060-01-100
6,00	11,00	4,50				x							HW..... 0060-02-100
6,00	12,00	2,00										x	HW..... 0060-03-100
6,00	12,00	4,50	x										HW..... 0060-04-100
6,00	14,00	6,00	x										HW..... 0060-05-100
6,00	15,00	4,00	x										HW..... 0060-06-100
6,00	16,00	5,00		x									HW..... 0060-07-100
6,00	16,00	7,00	x										HW..... 0060-08-100
6,00	18,00	8,00									x		HW..... 0060-09-100
6,00	19,00	5,00	x										HW..... 0060-10-100
6,00	19,00	6,00	x										HW..... 0060-11-100
6,00	19,00	7,00	x										HW..... 0060-12-100
6,00	22,00	7,00	x										HW..... 0060-13-100
7,00	11,00	2,00										x	HW..... 0070-01-100
7,00	14,00	2,00										x	HW..... 0070-02-100
7,00	14,00	5,00	x										HW..... 0070-03-100
7,00	15,00	5,00	x										HW..... 0070-04-100
7,00	16,00	7,00	x										HW..... 0070-05-100
7,00	18,00	8,00		x									HW..... 0070-06-100
7,00	22,00	7,00	x										HW..... 0070-07-100
7,80	13,70	2,50								x			HW..... 0078-01-100
8,00	12,00	3,00										x	HW..... 0080-01-100
8,00	15,00	3,00										x	HW..... 0080-02-100
8,00	16,00	3,50								x			HW..... 0080-03-100
8,00	16,00	5,00				x	x						HW..... 0080-04-100
8,00	16,00	7,00	x	x									HW..... 0080-05-100
8,00	16,00	10,00									x		HW..... 0080-06-100
8,00	18,00	5,00	x										HW..... 0080-07-100
8,00	18,00	6,00	x	x									HW..... 0080-08-100
8,00	22,00	7,00	x	x									HW..... 0080-09-100
8,00	22,00	8,00	x										HW..... 0080-10-100
8,00	24,00	7,00	x										HW..... 0080-11-100
8,00	25,00	7,00	x										HW..... 0080-12-100
8,50	18,00	7,00	x										HW..... 0085-01-100
9,00	13,00	3,00										x	HW..... 0090-01-100
9,00	16,00	3,00										x	HW..... 0090-02-100
9,00	18,00	7,00		x									HW..... 0090-03-100
9,00	18,00	8,00		x									HW..... 0090-04-100
9,00	20,00	6,00							x				HW..... 0090-05-100
9,00	22,00	7,00	x										HW..... 0090-06-100
9,00	24,00	7,00	x										HW..... 0090-07-100
9,00	26,00	7,00	x										HW..... 0090-08-100
10,00	14,00	3,00										x	HW..... 0100-01-100
10,00	16,00	5,00	x										HW..... 0100-02-100
10,00	16,50	4,00	x										HW..... 0100-03-100
10,00	17,00	3,00										x	HW..... 0100-04-100
10,00	18,00	4,00	x										HW..... 0100-05-100
10,00	18,00	4,80		x									HW..... 0100-06-100
10,00	18,00	6,00	x										HW..... 0100-07-100
10,00	19,00	7,00	x	x									HW..... 0100-08-100











Ø d h11	Ø D H8	E +0,3											Teile-Nr.
			400	410	420	430	440	450	460	470	480	500	
10,00	19,00	9,00		x									HW..... 0100-09-100
10,00	21,00	4,00								x			HW..... 0100-10-100
10,00	22,00	3,00										x	HW..... 0100-11-100
10,00	22,00	6,00	x	x					x				HW..... 0100-12-100
10,00	22,00	7,00	x										HW..... 0100-13-100
10,00	24,00	7,00	x										HW..... 0100-14-100
10,00	26,00	5,50	x										HW..... 0100-15-100
10,00	26,00	7,00	x	x					x				HW..... 0100-16-100
10,00	30,00	7,00	x										HW..... 0100-17-100
11,00	17,00	4,00	x										HW..... 0110-01-100
11,00	22,00	7,00	x										HW..... 0110-02-100
11,00	26,00	7,00	x										HW..... 0110-03-100
11,00	30,00	7,00		x									HW..... 0110-04-100
12,00	16,00	3,00								x		x	HW..... 0120-01-100
12,00	18,00	3,00										x	HW..... 0120-02-100
12,00	18,00	4,00								x			HW..... 0120-03-100
12,00	18,00	4,50		x									HW..... 0120-04-100
12,00	18,35	3,00								x			HW..... 0120-05-100
12,00	19,00	3,00								x		x	HW..... 0120-06-100
12,00	19,00	4,00						x					HW..... 0120-07-100
12,00	19,00	5,00	x										HW..... 0120-08-100
12,00	20,00	4,50						x					HW..... 0120-09-100
12,00	20,00	5,00		x									HW..... 0120-10-100
12,00	22,00	4,00	x										HW..... 0120-11-100
12,00	22,00	5,00	x										HW..... 0120-12-100
12,00	22,00	6,50							x				HW..... 0120-13-100
12,00	22,00	7,00	x	x									HW..... 0120-14-100
12,00	22,00	7,50							x				HW..... 0120-15-100
12,00	24,00	4,50	x										HW..... 0120-16-100
12,00	24,00	6,00	x										HW..... 0120-17-100
12,00	24,00	7,00	x	x									HW..... 0120-18-100
12,00	24,00	10,00									x		HW..... 0120-19-100
12,00	25,00	4,50	x										HW..... 0120-20-100
12,00	25,00	8,00	x										HW..... 0120-21-100
12,00	26,00	8,00	x										HW..... 0120-22-100
12,00	28,00	5,00	x										HW..... 0120-23-100
12,00	28,00	7,00	x	x									HW..... 0120-24-100
12,00	30,00	7,00	x	x				x					HW..... 0120-25-100
12,00	32,00	7,00	x										HW..... 0120-26-100
12,00	35,00	7,00	x										HW..... 0120-27-100
12,50	19,00	5,00	x										HW..... 0125-01-100
12,50	20,00	5,00	x										HW..... 0125-02-100
12,50	20,00	6,00	x										HW..... 0125-03-100
12,50	22,00	4,50	x										HW..... 0125-04-100
12,50	22,00	5,00	x										HW..... 0125-05-100
12,70	22,23	6,35		x									HW..... 0127-01-100
12,70	26,00	6,00	x										HW..... 0127-02-100
12,80	19,40	2,50								x			HW..... 0128-01-100
13,00	19,00	3,00								x		x	HW..... 0130-01-100
13,00	20,00	4,00						x	x				HW..... 0130-02-100
13,00	22,00	4,00	x										HW..... 0130-03-100
13,00	22,00	5,00	x										HW..... 0130-04-100
13,00	22,00	7,00		x									HW..... 0130-05-100
13,00	26,00	5,00	x										HW..... 0130-06-100
13,00	30,00	7,00	x										HW..... 0130-07-100
13,00	35,00	10,00	x										HW..... 0130-08-100
14,00	20,00	3,00										x	HW..... 0140-01-100
14,00	21,00	3,00										x	HW..... 0140-02-100
14,00	22,00	3,00										x	HW..... 0140-03-100
14,00	22,00	4,00	x										HW..... 0140-04-100











Ø d h11	Ø D H8	E +0,3											Teile-Nr.
			400	410	420	430	440	450	460	470	480	500	
14,00	22,00	5,00		x									HW..... 0140-05-100
14,00	24,00	5,00		x									HW..... 0140-06-100
14,00	24,00	6,00						x					HW..... 0140-07-100
14,00	24,00	7,00	x	x									HW..... 0140-08-100
14,00	28,00	7,00	x	x									HW..... 0140-09-100
14,00	30,00	7,00	x										HW..... 0140-10-100
14,00	30,00	8,00	x										HW..... 0140-11-100
14,00	30,00	10,00		x									HW..... 0140-12-100
14,00	35,00	7,00	x										HW..... 0140-13-100
14,00	35,00	10,00	x										HW..... 0140-14-100
15,00	21,00	2,00										x	HW..... 0150-01-100
15,00	21,00	3,00								x		x	HW..... 0150-02-100
15,00	21,00	5,00	x										HW..... 0150-03-100
15,00	22,00	5,00						x					HW..... 0150-04-100
15,00	23,00	3,00										x	HW..... 0150-05-100
15,00	24,00	5,00	x										HW..... 0150-06-100
15,00	24,00	6,00		x									HW..... 0150-07-100
15,00	24,00	7,00	x	x					x				HW..... 0150-08-100
15,00	25,00	3,00								x			HW..... 0150-09-100
15,00	25,00	5,00	x										HW..... 0150-10-100
15,00	25,00	7,00	x										HW..... 0150-11-100
15,00	25,40	5/7		x									HW..... 0150-12-100
15,00	25,50	4,60	x										HW..... 0150-13-100
15,00	26,00	7,00	x	x				x					HW..... 0150-14-100
15,00	27,00	7,00	x	x									HW..... 0150-15-100
15,00	28,00	4,00	x										HW..... 0150-16-100
15,00	28,00	6,00	x										HW..... 0150-17-100
15,00	28,00	7,00									x		HW..... 0150-18-100
15,00	30,00	4,50	x										HW..... 0150-19-100
15,00	30,00	7,00	x										HW..... 0150-20-100
15,00	30,00	10,00	x	x									HW..... 0150-21-100
15,00	32,00	7,00	x										HW..... 0150-22-100
15,00	32,00	7,00		x									HW..... 0150-23-100
15,00	35,00	6/7						x					HW..... 0150-24-100
15,00	35,00	5,00	x										HW..... 0150-25-100
15,00	35,00	6,00						x	x				HW..... 0150-26-100
15,00	35,00	7,00	x	x									HW..... 0150-27-100
15,00	35,00	8,00	x										HW..... 0150-28-100
15,00	35,00	10,00	x										HW..... 0150-29-100
15,00	40,00	10,00	x										HW..... 0150-30-100
15,00	42,00	7,00	x										HW..... 0150-31-100
15,00	42,00	10,00									x		HW..... 0150-32-100
15,00	50,00	7,00	x										HW..... 0150-33-100
16,00	22,00	3,00										x	HW..... 0160-01-100
16,00	22,20	4,00	x										HW..... 0160-02-100
16,00	22,70	2,00								x			HW..... 0160-03-100
16,00	24,00	3,00								x		x	HW..... 0160-04-100
16,00	24,00	5,00	x										HW..... 0160-05-100
16,00	25,00	3,00										x	HW..... 0160-06-100
16,00	26,00	7,00	x										HW..... 0160-07-100
16,00	28,00	7,00	x	x					x				HW..... 0160-08-100
16,00	30,00	5,00	x										HW..... 0160-09-100
16,00	30,00	6,00	x										HW..... 0160-10-100
16,00	30,00	6,60	x										HW..... 0160-11-100
16,00	30,00	7,00	x										HW..... 0160-12-100
16,00	32,00	7,00	x										HW..... 0160-13-100
16,00	32,00	9,00	x										HW..... 0160-14-100
16,00	35,00	6/8									x		HW..... 0160-15-100
16,00	35,00	7,00	x										HW..... 0160-16-100
16,00	35,00	10,00	x										HW..... 0160-17-100

Ø d h11	Ø D H8	E +0,3											Teile-Nr.
			400	410	420	430	440	450	460	470	480	500	
16,00	40,00	10,00	x										HW..... 0160-18-100
17,00	23,00	3,00										x	HW..... 0170-01-100
17,00	25,00	3,00										x	HW..... 0170-02-100
17,00	25,00	4,00	x										HW..... 0170-03-100
17,00	26,00	6,00	x										HW..... 0170-04-100
17,00	28,00	6,00	x										HW..... 0170-05-100
17,00	28,00	7,00	x	x				x		x			HW..... 0170-06-100
17,00	28,00	7,30	x										HW..... 0170-07-100
17,00	28,00	8,00	x									x	HW..... 0170-08-100
17,00	30,00	5,00	x	x									HW..... 0170-09-100
17,00	30,00	7,00	x	x									HW..... 0170-10-100
17,00	32,00	5,00	x										HW..... 0170-11-100
17,00	32,00	7,00	x										HW..... 0170-12-100
17,00	35,00	7,00	x	x						x			HW..... 0170-13-100
17,00	35,00	8,00	x	x									HW..... 0170-14-100
17,00	37,00	4,00	x										HW..... 0170-15-100
17,00	40,00	7/7,5								x			HW..... 0170-16-100
17,00	40,00	7,00	x	x									HW..... 0170-17-100
17,00	40,00	8,50	x										HW..... 0170-18-100
17,00	40,00	10,00	x										HW..... 0170-19-100
17,00	47,00	7,00	x										HW..... 0170-20-100
17,46	23,81	3,18								x			HW..... 0175-01-100
17,46	31,75	7,93									x		HW..... 0175-02-100
17,80	26,20	3,50	x										HW..... 0178-01-100
18,00	24,00	3,00										x	HW..... 0180-01-100
18,00	24,00	4,00								x		x	HW..... 0180-02-100
18,00	26,00	4,00										x	HW..... 0180-03-100
18,00	27,00	4,00										x	HW..... 0180-04-100
18,00	28,00	7,00	x	x									HW..... 0180-05-100
18,00	30,00	5,00	x										HW..... 0180-06-100
18,00	30,00	7,00	x	x									HW..... 0180-07-100
18,00	30,00	8,00									x		HW..... 0180-08-100
18,00	32,00	7,00	x	x									HW..... 0180-09-100
18,00	32,00	8,00	x								x		HW..... 0180-10-100
18,00	35,00	7,00	x										HW..... 0180-11-100
18,00	35,00	8,00	x										HW..... 0180-12-100
18,00	35,00	10,00	x										HW..... 0180-13-100
18,00	40,00	7,00	x										HW..... 0180-14-100
19,00	27,00	4,00										x	HW..... 0190-01-100
19,00	27,00	6,00	x										HW..... 0190-02-100
19,00	27,20	5,00								x			HW..... 0190-03-100
19,00	30,00	7,00		x				x					HW..... 0190-04-100
19,00	30,50	8,5/11,5		x									HW..... 0190-05-100
19,00	32,00	7,00	x	x									HW..... 0190-06-100
19,00	32,00	10,00	x	x									HW..... 0190-07-100
19,00	35,00	10,00	x										HW..... 0190-08-100
19,00	42,00	7,00	x										HW..... 0190-09-100
19,00	47,00	10,00	x										HW..... 0190-10-100
20,00	26,00	4,00								x		x	HW..... 0200-01-100
20,00	28,00	4,00	x							x		x	HW..... 0200-02-100
20,00	28,00	6,00	x						x				HW..... 0200-03-100
20,00	28,00	7,00	x										HW..... 0200-04-100
20,00	30,00	4,00	x										HW..... 0200-05-100
20,00	30,00	5,00	x	x									HW..... 0200-06-100
20,00	30,00	6,00	x										HW..... 0200-07-100
20,00	30,00	7,00	x	x									HW..... 0200-08-100
20,00	31,00	7,00							x				HW..... 0200-09-100
20,00	32,00	7,00	x	x				x					HW..... 0200-10-100
20,00	34,10	10/13		x									HW..... 0200-11-100
20,00	35,00	7/7,5							x				HW..... 0200-12-100











Ø d h11	Ø D H8	E +0,3											Teile-Nr.
			400	410	420	430	440	450	460	470	480	500	
20,00	35,00	5,00	x										HW..... 0200-13-100
20,00	35,00	6,00		x					x				HW..... 0200-14-100
20,00	35,00	7,00	x	x									HW..... 0200-15-100
20,00	35,00	8,00	x										HW..... 0200-16-100
20,00	35,00	10,00	x										HW..... 0200-17-100
20,00	37,00	8,00	x										HW..... 0200-18-100
20,00	38,00	7,00	x										HW..... 0200-19-100
20,00	38,00	8,00	x	x									HW..... 0200-20-100
20,00	40,00	8/13						x					HW..... 0200-21-100
20,00	40,00	6,00		x									HW..... 0200-22-100
20,00	40,00	7,00	x	x									HW..... 0200-23-100
20,00	40,00	8,00	x										HW..... 0200-24-100
20,00	40,00	10,00	x										HW..... 0200-25-100
20,00	42,00	6,00	x	x									HW..... 0200-26-100
20,00	42,00	7,00	x	x									HW..... 0200-27-100
20,00	42,00	10,00	x	x									HW..... 0200-28-100
20,00	45,00	7,00		x									HW..... 0200-29-100
20,00	47,00	7,00	x	x									HW..... 0200-30-100
20,00	47,00	8,00	x										HW..... 0200-31-100
20,00	47,00	10,00	x		x			x					HW..... 0200-32-100
20,00	48,40	7,00	x										HW..... 0200-33-100
20,00	52,00	7,00	x										HW..... 0200-34-100
20,00	52,00	10,00	x	x									HW..... 0200-35-100
20,00	72,00	10,00	x										HW..... 0200-36-100
20,40	27,15	2,00								x			HW..... 0204-01-100
21,00	29,00	4,00										x	HW..... 0210-01-100
21,00	40,00	7,00		x									HW..... 0210-02-100
21,80	38,10	6,35	x										HW..... 0218-01-100
22,00	28,00	4,00										x	HW..... 0220-01-100
22,00	30,00	4,00										x	HW..... 0220-02-100
22,00	32,00	7/9						x					HW..... 0220-03-100
22,00	32,00	5,50	x										HW..... 0220-04-100
22,00	32,00	7,00	x	x					x				HW..... 0220-05-100
22,00	35,00	10/13		x									HW..... 0220-06-100
22,00	35,00	6/6,5							x				HW..... 0220-07-100
22,00	35,00	7,00	x	x									HW..... 0220-08-100
22,00	35,00	8,00	x										HW..... 0220-09-100
22,00	35,00	10,00	x	x									HW..... 0220-10-100
22,00	40,00	8/11,5		x									HW..... 0220-11-100
22,00	40,00	7,00	x	x									HW..... 0220-12-100
22,00	40,00	8,00	x										HW..... 0220-13-100
22,00	42,00	10,00			x								HW..... 0220-14-100
22,00	45,00	7,00	x										HW..... 0220-15-100
22,00	47,00	7,00	x	x									HW..... 0220-16-100
22,00	47,00	10,00	x										HW..... 0220-17-100
22,00	62,00	7,00	x										HW..... 0220-18-100
22,20	34,90	6,35	x										HW..... 0222-01-100
22,23	38,10	6,35	x										HW..... 0222-02-100
22,70	47,00	7,00	x										HW..... 0227-01-100
23,00	30,00	4,00								x			HW..... 0230-01-100
23,00	47,00	10,00	x	x									HW..... 0230-02-100
23,70	45,00	8,00						x					HW..... 0237-01-100
23,81	36,51	6,35	x										HW..... 0238-01-100
24,00	32,00	4,00										x	HW..... 0240-01-100
24,00	35,00	7,00	x					x					HW..... 0240-02-100
24,00	36,00	7,00	x	x									HW..... 0240-03-100
24,00	37,00	7,00	x										HW..... 0240-04-100
24,00	40,00	7,00	x	x					x				HW..... 0240-05-100
24,00	40,00	8,00		x									HW..... 0240-06-100
24,00	40,00	10,00	x										HW..... 0240-07-100











Ø d h11	Ø D H8	E +0,3											Teile-Nr.
			400	410	420	430	440	450	460	470	480	500	
24,00	42,00	8,00	x										HW..... 0240-08-100
24,00	45,00	7,00		x									HW..... 0240-09-100
24,00	47,00	7,00	x										HW..... 0240-10-100
24,00	48,00	10,00	x										HW..... 0240-11-100
24,00	50,00	10,00	x										HW..... 0240-12-100
24,00	52,00	10,00	x										HW..... 0240-13-100
24,50	33,00	5,00	x										HW..... 0245-01-100
24,50	40,00	8,50	x										HW..... 0245-02-100
24,90	45,00	6,50	x										HW..... 0249-01-100
25,00	32,00	4,00										x	HW..... 0250-01-100
25,00	32,00	5,00					x						HW..... 0250-02-100
25,00	32,00	6,00	x										HW..... 0250-03-100
25,00	33,00	4,00	x									x	HW..... 0250-04-100
25,00	35,00	6/6,5							x				HW..... 0250-05-100
25,00	35,00	4,00								x		x	HW..... 0250-06-100
25,00	35,00	5,00	x										HW..... 0250-07-100
25,00	35,00	6,00	x						x				HW..... 0250-08-100
25,00	35,00	7,00	x	x									HW..... 0250-09-100
25,00	35,00	8,50	x										HW..... 0250-10-100
25,00	37,00	5,00	x										HW..... 0250-11-100
25,00	37,00	7,00	x	x									HW..... 0250-12-100
25,00	38,00	7,00	x	x									HW..... 0250-13-100
25,00	40,00	10/9,5										x	HW..... 0250-14-100
25,00	40,00	7,00	x	x			x						HW..... 0250-15-100
25,00	40,00	8,00	x	x								x	HW..... 0250-16-100
25,00	42,00	6,00	x										HW..... 0250-17-100
25,00	42,00	7,00	x	x									HW..... 0250-18-100
25,00	42,00	8,50	x	x									HW..... 0250-19-100
25,00	42,00	10,00	x	x									HW..... 0250-20-100
25,00	42,00	14,00										x	HW..... 0250-21-100
25,00	43,00	9,00	x										HW..... 0250-22-100
25,00	45,00	10,00	x										HW..... 0250-23-100
25,00	46,00	7,00	x										HW..... 0250-24-100
25,00	47,00	8/11,5		x									HW..... 0250-25-100
25,00	47,00	7,00	x	x									HW..... 0250-26-100
25,00	47,00	8,00	x										HW..... 0250-27-100
25,00	47,00	8,70		x									HW..... 0250-28-100
25,00	47,00	10,00	x	x	x								HW..... 0250-29-100
25,00	47,00	12,00										x	HW..... 0250-30-100
25,00	49,00	10/15		x									HW..... 0250-31-100
25,00	50,00	10,00	x	x									HW..... 0250-32-100
25,00	52,00	5,00	x										HW..... 0250-33-100
25,00	52,00	7,00	x	x									HW..... 0250-34-100
25,00	52,00	8,00	x	x									HW..... 0250-35-100
25,00	52,00	10,00	x	x	x								HW..... 0250-36-100
25,00	62,00	7,00		x									HW..... 0250-37-100
25,00	62,00	10,00	x	x									HW..... 0250-38-100
25,40	35,00	7,00		x									HW..... 0254-01-100
25,40	36,52	6,35							x				HW..... 0254-02-100
25,40	38,18	6,50					x						HW..... 0254-03-100
25,40	41,35	6,35					x						HW..... 0254-04-100
25,40	44,45	9,53	x										HW..... 0254-05-100
25,40	52,00	7,00		x									HW..... 0254-06-100
25,70	35,00	7/9						x					HW..... 0257-01-100
26,00	34,00	4,00										x	HW..... 0260-01-100
26,00	35,00	7,00	x	x			x						HW..... 0260-02-100
26,00	36,00	7,00	x	x									HW..... 0260-03-100
26,00	37,00	7/8		x									HW..... 0260-04-100
26,00	37,00	7,00	x										HW..... 0260-05-100
26,00	42,00	7,00	x										HW..... 0260-06-100











Ø d h11	Ø D H8	E +0,3											Teile-Nr.
			400	410	420	430	440	450	460	470	480	500	
26,00	47,00	7,00	x										HW..... 0260-07-100
26,00	50,00	10,00	x										HW..... 0260-08-100
26,00	50,00	12,00			x								HW..... 0260-09-100
26,00	52,00	8,00	x										HW..... 0260-10-100
26,00	52,00	10,00		x									HW..... 0260-11-100
26,50	47,00	7,00	x										HW..... 0265-01-100
27,00	37,00	7,00	x										HW..... 0270-01-100
27,00	41,00	10,00	x										HW..... 0270-02-100
27,00	47,00	10/12		x									HW..... 0270-03-100
27,00	47,00	6,00	x										HW..... 0270-04-100
27,00	47,00	7,00	x	x									HW..... 0270-05-100
27,00	51,00	10,00		x									HW..... 0270-06-100
28,00	35,00	4,00										x	HW..... 0280-01-100
28,00	37,00	4,00										x	HW..... 0280-02-100
28,00	38,00	6,00	x										HW..... 0280-03-100
28,00	38,00	7,00	x	x									HW..... 0280-04-100
28,00	40,00	8/8,5							x				HW..... 0280-05-100
28,00	40,00	7,00	x	x					x				HW..... 0280-06-100
28,00	40,00	10,00	x										HW..... 0280-07-100
28,00	42,00	7,00	x				x						HW..... 0280-08-100
28,00	42,00	10,00	x										HW..... 0280-09-100
28,00	43,00	10,00	x										HW..... 0280-10-100
28,00	47,00	7,00	x	x									HW..... 0280-11-100
28,00	47,00	8,00	x										HW..... 0280-12-100
28,00	47,00	10,00	x										HW..... 0280-13-100
28,00	50,00	10,00	x										HW..... 0280-14-100
28,00	52,00	5,00	x										HW..... 0280-15-100
28,00	52,00	6,00	x										HW..... 0280-16-100
28,00	52,00	7,00	x										HW..... 0280-17-100
28,00	52,00	10,00	x	x									HW..... 0280-18-100
28,00	57,00	12,00	x										HW..... 0280-19-100
28,00	62,00	12,00	x										HW..... 0280-20-100
28,45	38,10	6,35	x										HW..... 0285-01-100
28,57	45,24	6,35		x									HW..... 0286-01-100
28,58	38,10	6,35	x										HW..... 0286-02-100
28,58	41,28	9,52		x									HW..... 0286-03-100
29,00	38,00	4,00										x	HW..... 0290-01-100
29,00	40,00	7,00	x										HW..... 0290-02-100
29,00	45,00	9,50	x										HW..... 0290-03-100
30,00	37,00	4,00										x	HW..... 0300-01-100
30,00	38,00	5,00					x						HW..... 0300-02-100
30,00	40,00	4,00	x							x		x	HW..... 0300-03-100
30,00	40,00	5,00	x										HW..... 0300-04-100
30,00	40,00	7,00	x	x									HW..... 0300-05-100
30,00	42,00	6,00		x									HW..... 0300-06-100
30,00	42,00	7,00	x	x					x				HW..... 0300-07-100
30,00	42,00	8,00		x									HW..... 0300-08-100
30,00	43,00	8,00					x						HW..... 0300-09-100
30,00	44,00	10,00	x	x									HW..... 0300-10-100
30,00	45,00	5,00	x										HW..... 0300-11-100
30,00	45,00	8,00	x										HW..... 0300-12-100
30,00	47,00	5,00	x										HW..... 0300-13-100
30,00	47,00	6,00	x										HW..... 0300-14-100
30,00	47,00	7,00	x	x					x				HW..... 0300-15-100
30,00	47,00	8,00	x	x									HW..... 0300-16-100
30,00	47,00	10,00	x	x									HW..... 0300-17-100
30,00	48,00	8,00	x										HW..... 0300-18-100
30,00	50,00	5,00	x										HW..... 0300-19-100
30,00	50,00	7,00	x						x				HW..... 0300-20-100











Ø d h11	Ø D H8	E +0,3											Teile-Nr.
			400	410	420	430	440	450	460	470	480	500	
30,00	50,00	8,00	x	x									HW..... 0300-21-100
30,00	50,00	10,00	x	x	x								HW..... 0300-22-100
30,00	50,00	12,00			x								HW..... 0300-23-100
30,00	52,00	10/12		x									HW..... 0300-24-100
30,00	52,00	4,00	x										HW..... 0300-25-100
30,00	52,00	7,00	x	x				x					HW..... 0300-26-100
30,00	52,00	10,00	x	x									HW..... 0300-27-100
30,00	53,50	12/17,5		x									HW..... 0300-28-100
30,00	53,50	10/14		x									HW..... 0300-29-100
30,00	55,00	7/9							x				HW..... 0300-30-100
30,00	55,00	7,00	x										HW..... 0300-31-100
30,00	55,00	10,00	x	x									HW..... 0300-32-100
30,00	55,00	12,00					x						HW..... 0300-33-100
30,00	56,00	10,00	x										HW..... 0300-34-100
30,00	56,00	12,00			x								HW..... 0300-35-100
30,00	60,00	10,00	x										HW..... 0300-36-100
30,00	62,00	7,00	x	x									HW..... 0300-37-100
30,00	62,00	10,00	x	x	x								HW..... 0300-38-100
30,00	68,00	7,00	x										HW..... 0300-39-100
30,00	72,00	10,00	x										HW..... 0300-40-100
30,00	43,64	13,90						x					HW..... 0300-41-100
30,20	50,70	6,35	x										HW..... 0302-01-100
31,00	47,00	7,00	x										HW..... 0310-01-100
31,00	52,00	7,00	x	x									HW..... 0310-02-100
31,00	62,00	4/5	x										HW..... 0310-03-100
31,50	47,00	7,00	x										HW..... 0310-04-100
31,75	40,00	7,00		x									HW..... 0318-01-100
31,75	41,27	6,35		x									HW..... 0318-02-100
31,75	44,60	6,35	x										HW..... 0318-03-100
31,75	47,75	9,6/10,7	x										HW..... 0318-04-100
31,75	50,80	10,00									x		HW..... 0318-05-100
31,75	62,00	7,00		x									HW..... 0318-06-100
32,00	42,00	4,00										x	HW..... 0320-01-100
32,00	42,00	7,00	x	x									HW..... 0320-02-100
32,00	45,00	4,00										x	HW..... 0320-03-100
32,00	45,00	7,00	x	x									HW..... 0320-04-100
32,00	47,00	7,00	x					x	x				HW..... 0320-05-100
32,00	47,00	8,00	x										HW..... 0320-06-100
32,00	47,00	12,00									x		HW..... 0320-07-100
32,00	48,00	7,00		x									HW..... 0320-08-100
32,00	50,00	8,00	x		x								HW..... 0320-09-100
32,00	50,00	10,00	x										HW..... 0320-10-100
32,00	52,00	10/12		x									HW..... 0320-11-100
32,00	52,00	5,00	x										HW..... 0320-12-100
32,00	52,00	7,00	x	x				x					HW..... 0320-13-100
32,00	52,00	7,50	x										HW..... 0320-14-100
32,00	52,00	10,00	x										HW..... 0320-15-100
32,00	52,00	12,00	x										HW..... 0320-16-100
32,00	56,00	10,00	x										HW..... 0320-17-100
32,00	62,00	6/7	x										HW..... 0320-18-100
32,00	62,00	10,00	x	x									HW..... 0320-19-100
32,00	70,00	8,00	x										HW..... 0320-20-100
33,00	45,00	10,00		x									HW..... 0330-01-100
33,00	47,00	11,00	x										HW..... 0330-02-100
33,00	50,00	6,00		x									HW..... 0330-03-100
33,00	50,00	10,00		x									HW..... 0330-04-100
33,00	52,00	6,00	x										HW..... 0330-05-100
33,00	72,00	12,00			x								HW..... 0330-06-100
33,50	50,00	6,00		x									HW..... 0335-01-100
34,00	46,00	10,00	x										HW..... 0340-01-100











Ø d h11	Ø D H8	E +0,3												Teile-Nr.			
			400	410	420	430	440	450	460	470	480	500					
34,00	50,00	10,00	x														HW..... 0340-02-100
34,00	52,00	10/12		x													HW..... 0340-03-100
34,00	52,00	8,00	x														HW..... 0340-04-100
34,00	52,00	10,00	x														HW..... 0340-05-100
34,00	62,00	10,00	x														HW..... 0340-06-100
34,90	46,50	7,00						x									HW..... 0349-01-100
34,90	50,80	11,10		x													HW..... 0349-02-100
34,90	53,90	7,90	x														HW..... 0349-03-100
34,90	60,30	12,70	x														HW..... 0349-04-100
35,00	42,00	4,00													x		HW..... 0350-01-100
35,00	42,00	5,00						x									HW..... 0350-02-100
35,00	45,00	4,00													x		HW..... 0350-03-100
35,00	45,00	6,00	x														HW..... 0350-04-100
35,00	45,00	7,00	x	x													HW..... 0350-05-100
35,00	45,00	10,00	x														HW..... 0350-06-100
35,00	47,00	4,50	x														HW..... 0350-07-100
35,00	47,00	6,00	x														HW..... 0350-08-100
35,00	47,00	7,00	x	x													HW..... 0350-09-100
35,00	47,00	10,00	x	x													HW..... 0350-10-100
35,00	50,00	7,00	x							x							HW..... 0350-11-100
35,00	50,00	8,00	x	x													HW..... 0350-12-100
35,00	50,00	10,00	x	x													HW..... 0350-13-100
35,00	52,00	6,00		x						x							HW..... 0350-14-100
35,00	52,00	7,00	x	x													HW..... 0350-15-100
35,00	52,00	8,00	x	x													HW..... 0350-16-100
35,00	52,00	10,00	x	x													HW..... 0350-17-100
35,00	52,00	12,00											x				HW..... 0350-18-100
35,00	53,00	8,00	x														HW..... 0350-19-100
35,00	55,00	8,00	x														HW..... 0350-20-100
35,00	55,00	9,00		x													HW..... 0350-21-100
35,00	55,00	10,00	x														HW..... 0350-22-100
35,00	55,00	10,00		x													HW..... 0350-23-100
35,00	55,50	9,00	x														HW..... 0350-24-100
35,00	56,00	10,00	x	x													HW..... 0350-25-100
35,00	58,00	10,00	x	x													HW..... 0350-26-100
35,00	60,00	10,00	x	x													HW..... 0350-27-100
35,00	62,00	7,00	x	x						x							HW..... 0350-28-100
35,00	62,00	8,00	x	x													HW..... 0350-29-100
35,00	62,00	10,00	x	x													HW..... 0350-30-100
35,00	62,00	12,00		x													HW..... 0350-31-100
35,00	65,00	10,00	x														HW..... 0350-32-100
35,00	67,00	7,00	x														HW..... 0350-33-100
35,00	68,00	10,00	x	x													HW..... 0350-34-100
35,00	70,00	10,00	x														HW..... 0350-35-100
35,00	72,00	7,00		x													HW..... 0350-36-100
35,00	72,00	10,00	x	x													HW..... 0350-37-100
35,00	72,00	12,00	x	x	x												HW..... 0350-38-100
35,00	80,00	10,00	x	x													HW..... 0350-39-100
35,00	80,00	12,00	x														HW..... 0350-40-100
35,20	57,30	12,70			x												HW..... 0352-01-100
36,00	45,00	6,00	x														HW..... 0360-01-100
36,00	47,00	7,00	x	x													HW..... 0360-02-100
36,00	50,00	7,00	x														HW..... 0360-03-100
36,00	50,00	10,00	x														HW..... 0360-04-100
36,00	52,00	7,00	x														HW..... 0360-05-100
36,00	52,00	10,00		x													HW..... 0360-06-100
36,00	54,00	7,50	x														HW..... 0360-07-100
36,00	58,00	10,00	x														HW..... 0360-08-100
36,00	62,00	7,00	x														HW..... 0360-09-100
36,00	63,00	12,00					x										HW..... 0360-10-100











Ø d h11	Ø D H8	E +0,3											Teile-Nr.
			400	410	420	430	440	450	460	470	480	500	
36,00	68,00	10,00	x										HW..... 0360-11-100
36,51	52,58	7,93		x									HW..... 0365-01-100
37,00	47,00	4,00										x	HW..... 0370-01-100
38,00	48,00	4,00										x	HW..... 0370-02-100
38,00	50,00	7,00	x										HW..... 0380-01-100
38,00	52,00	7,00	x	x									HW..... 0380-02-100
38,00	52,00	10,00					x						HW..... 0380-03-100
38,00	54,00	5,00	x										HW..... 0380-04-100
38,00	54,00	10,00	x	x									HW..... 0380-05-100
38,00	55,00	7,00	x										HW..... 0380-06-100
38,00	55,00	10,00	x	x									HW..... 0380-07-100
38,00	56,00	10,00	x										HW..... 0380-08-100
38,00	62,00	7,00	x	x					x				HW..... 0380-09-100
38,00	62,00	10,00	x										HW..... 0380-10-100
38,00	72,00	10,00	x	x									HW..... 0380-11-100
38,10	50,29	12,70	x										HW..... 0381-01-100
38,10	60,32	9,52		x									HW..... 0381-02-100
40,00	47,00	4,00										x	HW..... 0400-01-100
40,00	48,00	4,00										x	HW..... 0400-02-100
40,00	50,00	4,00										x	HW..... 0400-03-100
40,00	50,00	7,00		x									HW..... 0400-04-100
40,00	52,00	5,00							x			x	HW..... 0400-05-100
40,00	52,00	7,00	x	x									HW..... 0400-06-100
40,00	52,00	10,00		x									HW..... 0400-07-100
40,00	54,00	7,00	x										HW..... 0400-08-100
40,00	55,00	7,00	x	x					x				HW..... 0400-09-100
40,00	55,00	8,00	x	x									HW..... 0400-10-100
40,00	55,00	10,00	x										HW..... 0400-11-100
40,00	56,00	6,00							x				HW..... 0400-12-100
40,00	56,00	8,00	x	x									HW..... 0400-13-100
40,00	56,00	8,50								x			HW..... 0400-14-100
40,00	56,00	10,00	x										HW..... 0400-15-100
40,00	58,00	10,00	x	x									HW..... 0400-16-100
40,00	60,00	7,00	x										HW..... 0400-17-100
40,00	60,00	10,00	x	x					x				HW..... 0400-18-100
40,00	62,00	6,00							x				HW..... 0400-19-100
40,00	62,00	7,00	x	x									HW..... 0400-20-100
40,00	62,00	10,00	x	x		x		x					HW..... 0400-21-100
40,00	63,00	10,00	x										HW..... 0400-22-100
40,00	63,50	12,50			x								HW..... 0400-23-100
40,00	65,00	10,00	x										HW..... 0400-24-100
40,00	65,00	12,00	x										HW..... 0400-25-100
40,00	68,00	8,00	x										HW..... 0400-26-100
40,00	68,00	10,00	x	x									HW..... 0400-27-100
40,00	70,00	10,00	x										HW..... 0400-28-100
40,00	72,00	7,00	x	x									HW..... 0400-29-100
40,00	72,00	10,00	x										HW..... 0400-30-100
40,00	80,00	7,00		x									HW..... 0400-31-100
40,00	80,00	10,00	x	x									HW..... 0400-32-100
40,00	82,57	13,00			x								HW..... 0400-33-100
40,00	90,00	9,00			x								HW..... 0400-34-100
40,00	90,00	10,00	x										HW..... 0400-35-100
40,00	90,00	12,00	x	x									HW..... 0400-36-100
40,00	95,00	10,00			x								HW..... 0400-37-100
40,08	50,85	4,10	x										HW..... 0401-01-100
41,27	66,67	9,52	x										HW..... 0413-01-100
41,27	60,33	9,52		x									HW..... 0413-02-100
42,00	52,00	4,00										x	HW..... 0420-01-100
42,00	52,00	8,00		x									HW..... 0420-02-100
42,00	55,00	7,00	x										HW..... 0420-03-100











Ø d h11	Ø D H8	E +0,3											Teile-Nr.
			400	410	420	430	440	450	460	470	480	500	
42.00	55.00	8.00	x										HW..... 0420-04-100
42.00	55.00	10.00		x									HW..... 0420-05-100
42.00	56.00	7.00	x	x									HW..... 0420-06-100
42.00	58.00	10.00	x										HW..... 0420-07-100
42.00	60.00	12.00	x										HW..... 0420-08-100
42.00	62.00	7/7,5							x				HW..... 0420-09-100
42.00	62.00	7.00	x	x									HW..... 0420-10-100
42.00	62.00	8.00	x	x									HW..... 0420-11-100
42.00	62.00	10.00	x	x									HW..... 0420-12-100
42.00	65.00	8.00			x								HW..... 0420-13-100
42.00	65.00	10.00	x										HW..... 0420-14-100
42.00	72.00	8.00	x										HW..... 0420-15-100
42.00	72.00	10.00	x										HW..... 0420-16-100
42.00	72.00	12.00			x								HW..... 0420-17-100
43.00	53.00	4.00										x	HW..... 0430-01-100
43.00	54.00	9.00		x									HW..... 0430-02-100
43.00	55.00	9.00		x									HW..... 0430-03-100
43.00	55.00	10.00		x									HW..... 0430-04-100
43.00	60.00	10.00	x										HW..... 0430-05-100
44.00	55.00	10.00									x		HW..... 0440-01-100
44.00	62.00	10.00		x									HW..... 0440-02-100
44.00	72.00	12.00	x										HW..... 0440-03-100
44.40	68.26	15/19	x										HW..... 0444-01-100
44.45	68.32	19.40									x		HW..... 0445-01-100
44.50	63.65	9.50					x						HW..... 0445-02-100
45.00	52.00	4.00										x	HW..... 0450-01-100
45.00	55.00	4.00										x	HW..... 0450-02-100
45.00	55.00	6.00	x										HW..... 0450-03-100
45.00	55.00	7.00	x										HW..... 0450-04-100
45.00	56.00	7.00	x										HW..... 0450-05-100
45.00	57.00	10.00		x									HW..... 0450-06-100
45.00	58.00	7.00		x									HW..... 0450-07-100
45.00	60.00	10/13		x									HW..... 0450-08-100
45.00	60.00	7/8		x									HW..... 0450-09-100
45.00	60.00	7.00	x	x									HW..... 0450-10-100
45.00	60.00	8.00	x	x									HW..... 0450-11-100
45.00	60.00	10.00	x										HW..... 0450-12-100
45.00	62.00	7.00	x						x				HW..... 0450-13-100
45.00	62.00	8.00	x							x			HW..... 0450-14-100
45.00	62.00	10.00	x	x	x								HW..... 0450-15-100
45.00	62.00	12.00	x										HW..... 0450-16-100
45.00	64.00	12.00				x							HW..... 0450-17-100
45.00	65.00	10/12		x									HW..... 0450-18-100
45.00	65.00	7.00							x				HW..... 0450-19-100
45.00	65.00	8.00	x	x					x				HW..... 0450-20-100
45.00	65.00	10.00	x	x	x			x					HW..... 0450-21-100
45.00	66.00	6.00	x										HW..... 0450-22-100
45.00	66.00	10.00	x										HW..... 0450-23-100
45.00	68.00	10.00	x										HW..... 0450-24-100
45.00	70.00	10.00	x										HW..... 0450-25-100
45.00	72.00	7.00	x										HW..... 0450-26-100
45.00	72.00	8.00	x	x									HW..... 0450-27-100
45.00	72.00	10.00	x										HW..... 0450-28-100
45.00	73.00	12.00	x										HW..... 0450-29-100
45.00	75.00	8.00	x	x									HW..... 0450-30-100
45.00	75.00	10.00	x	x									HW..... 0450-31-100
45.00	80.00	7.00		x									HW..... 0450-32-100
45.00	80.00	10.00	x	x									HW..... 0450-33-100
45.00	80.00	13.00	x										HW..... 0450-34-100
45.00	85.00	10.00	x	x									HW..... 0450-35-100











Ø d h11	Ø D H8	E +0,3											Teile-Nr.
			400	410	420	430	440	450	460	470	480	500	
45.00	90.00	8.00	x										HW..... 0450-36-100
45.00	90.00	10.00	x	x	x								HW..... 0450-37-100
45.00	100.00	10.00	x										HW..... 0450-38-100
46.00	64.00	8.00	x										HW..... 0460-01-100
46.00	64.00	14.00		x									HW..... 0460-02-100
46.00	65.00	10.00	x										HW..... 0460-03-100
46.80	61.30	4.00	x										HW..... 0468-01-100
47.00	58.00	6.00	x										HW..... 0470-01-100
47.00	65.00	10.00							x				HW..... 0470-02-100
47.00	67.00	10.00		x									HW..... 0470-03-100
47.00	70.00	10.00	x										HW..... 0470-04-100
47.00	75.00	12.00			x								HW..... 0470-05-100
47.00	77.00	8.00	x										HW..... 0470-06-100
48.00	62.00	8.00	x	x									HW..... 0480-01-100
48.00	65.00	10.00	x	x			x						HW..... 0480-02-100
48.00	67.00	10.00		x									HW..... 0480-03-100
48.00	68.00	10.00		x									HW..... 0480-04-100
48.00	68.00	12.00	x										HW..... 0480-05-100
48.00	68.00	14.00		x									HW..... 0480-06-100
48.00	72.00	8.00	x										HW..... 0480-07-100
48.00	72.00	10.00	x										HW..... 0480-08-100
48.00	72.00	15.00									x		HW..... 0480-09-100
48.00	80.00	10.00	x										HW..... 0480-10-100
49.00	65.00	10.00	x										HW..... 0490-01-100
49.20	79.38	9.65			x								HW..... 0492-01-100
49.50	60.00	8.00	x										HW..... 0495-01-100
50.00	58.00	4.00										x	HW..... 0500-01-100
50.00	58.00	5.00					x						HW..... 0500-02-100
50.00	62.00	5.00										x	HW..... 0500-03-100
50.00	65.00	8.00	x	x					x				HW..... 0500-04-100
50.00	65.00	10.00	x										HW..... 0500-05-100
50.00	68.00	8.00	x	x					x				HW..... 0500-06-100
50.00	68.00	8.50								x			HW..... 0500-07-100
50.00	68.00	10.00	x	x									HW..... 0500-08-100
50.00	70.00	8.00	x										HW..... 0500-09-100
50.00	70.00	10.00	x	x	x								HW..... 0500-10-100
50.00	70.00	12.00	x										HW..... 0500-11-100
50.00	72.00	8/10		x					x				HW..... 0500-12-100
50.00	72.00	6.00	x										HW..... 0500-13-100
50.00	72.00	7.00							x				HW..... 0500-14-100
50.00	72.00	8.00	x	x									HW..... 0500-15-100
50.00	72.00	10.00	x	x									HW..... 0500-16-100
50.00	72.00	12.00	x	x									HW..... 0500-17-100
50.00	72.00	14.00									x		HW..... 0500-18-100
50.00	75.00	10.00	x										HW..... 0500-19-100
50.00	75.00	12.00		x									HW..... 0500-20-100
50.00	80.00	8.00	x	x									HW..... 0500-21-100
50.00	80.00	10.00	x	x	x								HW..... 0500-22-100
50.00	80.00	13.00	x	x									HW..... 0500-23-100
50.00	80.00	15.00									x		HW..... 0500-24-100
50.00	85.00	10.00	x										HW..... 0500-25-100
50.00	90.00	10.00	x	x									HW..... 0500-26-100
50.00	90.00	13.00			x								HW..... 0500-27-100
50.00	95.00	10.00			x								HW..... 0500-28-100
50.00	110.00	12.00	x										HW..... 0500-29-100
50.40	76.20	12.70				x							HW..... 0504-01-100
50.80	69.85	12.70			x								HW..... 0508-01-100
50.80	69.93	12.70						x					HW..... 0508-02-100
50.80	76.20	10.00									x		HW..... 0508-03-100
50.80	76.20	12.70			x								HW..... 0508-04-100











Ø d h11	Ø D H8	E +0,3											Teile-Nr.
			400	410	420	430	440	450	460	470	480	500	
50,80	76,30	9,50	x										HW..... 0508-05-100
51,60	67,85	9,50	x										HW..... 0516-01-100
52,00	68,00	8,00	x										HW..... 0520-01-100
52,00	70,00	7,00	x										HW..... 0520-02-100
52,00	72,00	8,00	x										HW..... 0520-03-100
52,00	73,30	10,60	x										HW..... 0520-04-100
52,00	75,00	12,00	x										HW..... 0520-05-100
52,00	76,00	13,00	x										HW..... 0520-06-100
52,00	80,00	10,00	x	x									HW..... 0520-07-100
52,00	80,00	13,00			x								HW..... 0520-08-100
52,00	85,00	10,00	x	x									HW..... 0520-09-100
52,00	87,00	8,00	x										HW..... 0520-10-100
52,38	80,96	11,43	x										HW..... 0524-01-100
53,00	79,00	10,00	x										HW..... 0530-01-100
53,00	80,00	10,00	x										HW..... 0530-02-100
53,97	72,93	12,70		x									HW..... 0539-01-100
54,00	72,00	10,00		x									HW..... 0540-01-100
54,00	80,00	10,00			x								HW..... 0540-02-100
54,00	85,00	10,00	x	x									HW..... 0540-03-100
54,00	90,00	13,00	x										HW..... 0540-04-100
54,80	70,00	9/9,5							x				HW..... 0548-01-100
54,86	82,57	12,70	x										HW..... 0548-02-100
55,00	63,00	5,00										x	HW..... 0550-01-100
55,00	68,00	8,00	x										HW..... 0550-02-100
55,00	70,00	8,00	x						x				HW..... 0550-03-100
55,00	70,00	10,00	x	x									HW..... 0550-04-100
55,00	72,00	8/8,5							x				HW..... 0550-05-100
55,00	72,00	8,00	x	x									HW..... 0550-06-100
55,00	72,00	10,00	x	x									HW..... 0550-07-100
55,00	75,00	8,00	x										HW..... 0550-08-100
55,00	75,00	9,00	x										HW..... 0550-09-100
55,00	75,00	10,00	x	x									HW..... 0550-10-100
55,00	75,00	12,00	x										HW..... 0550-11-100
55,00	78,00	10,00	x										HW..... 0550-12-100
55,00	80,00	5,00	x										HW..... 0550-13-100
55,00	80,00	6,00	x										HW..... 0550-14-100
55,00	80,00	8,00	x	x	x								HW..... 0550-15-100
55,00	80,00	10,00	x	x		x							HW..... 0550-16-100
55,00	80,00	13,00			x								HW..... 0550-17-100
55,00	85,00	8,00	x										HW..... 0550-18-100
55,00	85,00	10,00	x	x									HW..... 0550-19-100
55,00	85,00	14,00		x									HW..... 0550-20-100
55,00	90,00	8,00	x	x									HW..... 0550-21-100
55,00	90,00	10,00	x	x									HW..... 0550-22-100
55,00	100,00	10,00		x									HW..... 0550-23-100
55,00	100,00	12,00	x										HW..... 0550-24-100
55,00	100,00	13,00	x										HW..... 0550-25-100
56,00	70,00	8,00	x										HW..... 0560-01-100
56,00	72,00	8,00	x										HW..... 0560-02-100
56,00	80,00	8,00	x										HW..... 0560-03-100
56,00	85,00	8,00	x										HW..... 0560-04-100
56,00	90,00	10,00		x									HW..... 0560-05-100
57,00	85,00	13,00	x										HW..... 0570-01-100
57,10	76,20	12,70						x					HW..... 0571-01-100
57,94	84,93	7,93	x										HW..... 0579-01-100
58,00	72,00	8,00	x										HW..... 0580-01-100
58,00	72,00	10,00	x	x									HW..... 0580-02-100
58,00	75,00	12,00			x								HW..... 0580-03-100
58,00	80,00	8,00	x										HW..... 0580-04-100
58,00	80,00	9,00		x									HW..... 0580-05-100











Ø d h11	Ø D H8	E +0,3											Teile-Nr.
			400	410	420	430	440	450	460	470	480	500	
58.00	80.00	10.00		x									HW..... 0580-06-100
58.00	80.00	12.00	x										HW..... 0580-07-100
58.00	85.00	10.00	x										HW..... 0580-08-100
58.00	90.00	10.00	x										HW..... 0580-09-100
58.00	90.00	13.00			x								HW..... 0580-10-100
60.00	70.00	7.00	x										HW..... 0600-01-100
60.00	70.00	10.00								x			HW..... 0600-02-100
60.00	75.00	7/7,5							x				HW..... 0600-03-100
60.00	75.00	8.00	x	x	x				x				HW..... 0600-04-100
60.00	80.00	7.00		x					x				HW..... 0600-05-100
60.00	80.00	8.00	x	x	x	x							HW..... 0600-06-100
60.00	80.00	10.00	x	x				x			x		HW..... 0600-07-100
60.00	80.00	12.00	x		x								HW..... 0600-08-100
60.00	85.00	8.00	x										HW..... 0600-09-100
60.00	85.00	10.00	x	x	x								HW..... 0600-10-100
60.00	85.00	13.00			x								HW..... 0600-11-100
60.00	85.10	12.00			x								HW..... 0600-12-100
60.00	90.00	7.00							x				HW..... 0600-13-100
60.00	90.00	8.00	x	x									HW..... 0600-14-100
60.00	90.00	10.00	x	x									HW..... 0600-16-100
60.00	110.00	13.00	x		x								HW..... 0600-17-100
60.33	88.90	12.70		x									HW..... 0603-01-100
62.00	70.00	10.00								x			HW..... 0620-01-100
62.00	80.00	12.00			x								HW..... 0620-03-100
62.00	82.00	10.00			x								HW..... 0620-04-100
62.00	85.00	7.00							x				HW..... 0620-05-100
62.00	85.00	10.00	x										HW..... 0620-06-100
62.00	90.00	10.00	x	x									HW..... 0620-07-100
62.00	100.00	12.00	x										HW..... 0620-08-100
63.00	80.00	9.00		x									HW..... 0630-01-100
63.00	85.00	10.00	x		x	x							HW..... 0630-02-100
63.00	90.00	10.00	x										HW..... 0630-03-100
63.00	90.00	13.00			x								HW..... 0630-04-100
63.50	85.72	6.35		x									HW..... 0635-01-100
63.50	85.72	12.70				x							HW..... 0635-02-100
64.00	80.00	8.00	x										HW..... 0640-01-100
64.00	85.00	13.00			x								HW..... 0640-02-100
65.00	75.00	8.00		x									HW..... 0650-01-100
65.00	80.00	8.00	x										HW..... 0650-02-100
65.00	80.00	10.00		x									HW..... 0650-03-100
65.00	85.00	8.00	x										HW..... 0650-04-100
65.00	85.00	10.00	x	x	x								HW..... 0650-05-100
65.00	90.00	10.00	x	x	x				x				HW..... 0650-06-100
65.00	90.00	12.00			x	x							HW..... 0650-07-100
65.00	95.00	10.00	x										HW..... 0650-08-100
65.00	100.00	10.00		x		x		x					HW..... 0650-09-100
65.00	125.00	12.00	x										HW..... 0650-10-100
65.09	88.90	12.70		x									HW..... 0651-01-100
66.00	90.00	10.00			x								HW..... 0660-01-100
68.00	90.00	10.00	x		x	x							HW..... 0680-01-100
68.00	95.00	13.00	x										HW..... 0680-02-100
68.00	97.00	8.00	x										HW..... 0680-03-100
68.00	100.00	10.00	x	x									HW..... 0680-04-100
68.00	100.00	12.00			x								HW..... 0680-05-100
68.00	100.00	13.00	x										HW..... 0680-06-100
68.00	110.00	13.00			x								HW..... 0680-07-100
70.00	78.00	5.00										x	HW..... 0700-01-100
70.00	81.50	6.00								x			HW..... 0700-02-100
70.00	85.00	7.00	x										HW..... 0700-03-100
70.00	85.00	8.00	x	x									HW..... 0700-04-100











Ø d h11	Ø D H8	E +0,3											Teile-Nr.
			400	410	420	430	440	450	460	470	480	500	
70,00	85,00	10,00	x	x									HW..... 0700-05-100
70,00	90,00	7,00							x				HW..... 0700-06-100
70,00	90,00	10,00	x	x	x	x			x		x		HW..... 0700-07-100
70,00	90,00	12,00	x										HW..... 0700-08-100
70,00	90,00	13,00			x						x		HW..... 0700-09-100
70,00	95,00	10,00	x										HW..... 0700-10-100
70,00	95,00	12,00		x									HW..... 0700-11-100
70,00	95,00	13,00	x			x							HW..... 0700-12-100
70,00	100,00	10,00	x	x	x				x				HW..... 0700-13-100
70,00	100,00	12,00	x										HW..... 0700-14-100
70,00	105,00	10,00	x										HW..... 0700-15-100
70,00	110,00	10,00	x	x									HW..... 0700-16-100
70,00	110,00	12,00	x	x									HW..... 0700-17-100
70,00	120,00	12,00	x										HW..... 0700-18-100
70,00	120,00	13,00	x		x								HW..... 0700-19-100
70,00	150,00	12,00	x										HW..... 0700-20-100
72,00	85,00	10,00	x										HW..... 0720-01-100
72,00	90,00	10,00	x	x		x							HW..... 0720-02-100
72,00	95,00	10,00	x		x								HW..... 0720-03-100
72,00	95,00	12,00	x										HW..... 0720-04-100
72,00	95,00	13,00			x								HW..... 0720-05-100
72,00	100,00	10,00	x	x									HW..... 0720-06-100
72,00	101,60	12,50	x										HW..... 0720-07-100
72,00	110,00	12,00	x										HW..... 0720-08-100
72,00	130,00	12,00	x										HW..... 0720-09-100
75,00	90,00	8,00	x	x									HW..... 0750-01-100
75,00	90,00	10,00	x	x					x				HW..... 0750-02-100
75,00	90,00	12,00	x										HW..... 0750-03-100
75,00	95,00	9,00		x									HW..... 0750-04-100
75,00	95,00	10,00	x	x					x				HW..... 0750-05-100
75,00	95,00	12,00	x										HW..... 0750-06-100
75,00	100,00	10,00	x	x	x								HW..... 0750-07-100
75,00	100,00	13,00				x					x		HW..... 0750-08-100
75,00	105,00	12,00	x			x							HW..... 0750-09-100
75,00	107,00	10,00	x										HW..... 0750-10-100
75,00	110,00	12,00	x	x									HW..... 0750-11-100
75,00	115,00	13,00				x							HW..... 0750-12-100
75,00	120,00	12,00	x										HW..... 0750-13-100
75,00	130,00	13,00	x										HW..... 0750-14-100
76,00	100,00	16,00		x									HW..... 0760-01-100
76,20	98,43	11,11			x								HW..... 0760-02-100
76,20	104,78	12,70									x		HW..... 0762-01-100
78,00	90,00	8,00	x										HW..... 0780-01-100
78,00	95,00	13,00			x								HW..... 0780-02-100
78,00	95,50	12,70	x										HW..... 0780-03-100
78,00	100,00	10,00	x	x									HW..... 0780-04-100
78,00	110,00	12,00	x										HW..... 0780-05-100
80,00	90,00	5,00								x		x	HW..... 0800-01-100
80,00	90,00	6,00								x			HW..... 0800-02-100
80,00	90,00	12,00								x			HW..... 0800-03-100
80,00	95,00	5,00					x						HW..... 0800-05-100
80,00	95,00	8,00	x										HW..... 0800-06-100
80,00	100,00	7,00							x				HW..... 0800-07-100
80,00	100,00	10,00	x	x	x	x							HW..... 0800-08-100
80,00	100,00	12,00									x		HW..... 0800-09-100
80,00	100,00	13,00	x	x	x								HW..... 0800-10-100
80,00	105,00	10,00	x										HW..... 0800-11-100
80,00	105,00	13,00	x										HW..... 0800-12-100
80,00	108,00	10,00				x							HW..... 0800-13-100
80,00	110,00	10,00	x	x									HW..... 0800-14-100











Ø d h11	Ø D H8	E +0,3											Teile-Nr.
			400	410	420	430	440	450	460	470	480	500	
80,00	110,00	12,00	x	x									HW..... 0800-15-100
80,00	110,00	13,00				x							HW..... 0800-16-100
80,00	110,00	14,00			x								HW..... 0800-17-100
80,00	120,00	13,00	x										HW..... 0800-18-100
80,00	125,00	10,00		x									HW..... 0800-19-100
80,00	125,00	12,00	x	x									HW..... 0800-20-100
80,00	150,50	13,00	x										HW..... 0800-21-100
82,00	105,00	10/12		x									HW..... 0820-01-100
82,00	105,00	12,00	x	x									HW..... 0820-02-100
82,00	105,00	13,00			x								HW..... 0820-03-100
82,00	110,00	12,00	x										HW..... 0820-04-100
83,50	105,00	13,00			x								HW..... 0835-01-100
84,00	105,00	13,00			x								HW..... 0840-01-100
84,00	110,00	12,00			x								HW..... 0840-02-100
85,00	100,00	9,00	x										HW..... 0850-01-100
85,00	102,00	13,00	x										HW..... 0850-02-100
85,00	105,00	12,00					x		x				HW..... 0850-03-100
85,00	105,00	13,00	x										HW..... 0850-04-100
85,00	110,00	12,00	x	x		x							HW..... 0850-05-100
85,00	110,00	13,00	x	x	x								HW..... 0850-06-100
85,00	110,00	15,00			x								HW..... 0850-07-100
85,00	115,00	15,00	x										HW..... 0850-08-100
85,00	120,00	7,50							x				HW..... 0850-09-100
85,00	120,00	12,00	x	x	x								HW..... 0850-10-100
85,00	120,00	13,00	x	x									HW..... 0850-11-100
85,00	120,00	15,00			x								HW..... 0850-12-100
85,00	125,00	13,00			x								HW..... 0850-13-100
85,00	130,00	12,00	x	x									HW..... 0850-14-100
85,00	140,00	12,00	x	x									HW..... 0850-15-100
87,00	110,00	10,00			x	x							HW..... 0870-01-100
88,00	105,00	12,00	x										HW..... 0880-01-100
88,00	110,00	12,00	x										HW..... 0880-02-100
88,00	113,00	8,00	x										HW..... 0880-03-100
88,00	120,00	10,00			x								HW..... 0880-04-100
88,00	120,00	13,00			x								HW..... 0880-05-100
88,00	140,00	12,00	x										HW..... 0880-06-100
88,00	150,00	13,00	x										HW..... 0880-07-100
88,80	114,28	12,70		x									HW..... 0888-01-100
88,90	114,30	11,90			x								HW..... 0889-01-100
88,90	120,70	10,00			x								HW..... 0889-02-100
88,90	127,00	12,70	x										HW..... 0889-03-100
89,00	120,00	13,00			x								HW..... 0890-01-100
89,70	105,00	6,00	x										HW..... 0897-01-100
90,00	105,00	10,00	x										HW..... 0900-01-100
90,00	110,00	7,50		x									HW..... 0900-02-100
90,00	110,00	8,00	x		x								HW..... 0900-03-100
90,00	110,00	10,00	x										HW..... 0900-04-100
90,00	110,00	12,00	x	x					x				HW..... 0900-05-100
90,00	110,00	13,00	x		x								HW..... 0900-06-100
90,00	115,00	9,00	x										HW..... 0900-07-100
90,00	115,00	13,00	x		x								HW..... 0900-08-100
90,00	118,00	12,00				x							HW..... 0900-09-100
90,00	120,00	12,00	x		x								HW..... 0900-10-100
90,00	120,00	13,00	x	x									HW..... 0900-11-100
90,00	120,00	15,00			x	x							HW..... 0900-12-100
90,00	125,00	12,00							x				HW..... 0900-13-100
90,00	130,00	12,00	x	x									HW..... 0900-14-100
90,00	130,00	13,00	x			x							HW..... 0900-15-100
90,00	160,00	12,00	x										HW..... 0900-16-100
92,00	120,00	10,00				x							HW..... 0920-01-100











Ø d h11	Ø D H8	E +0,3											Teile-Nr.
			400	410	420	430	440	450	460	470	480	500	
92,00	120,00	13,00	x	x	x								HW..... 0920-02-100
92,08	111,13	11,10		x									HW..... 0921-01-100
92,20	126,70	11,60			x								HW..... 0922-01-100
93,00	130,20	10,00			x								HW..... 0930-01-100
95,00	110,00	10,00	x										HW..... 0950-01-100
95,00	110,00	12,00	x										HW..... 0950-02-100
95,00	115,00	9,00			x								HW.....0950-03-100
95,00	115,00	10,00			x								HW..... 0950-04-100
95,00	115,00	13,00			x								HW..... 0950-05-100
95,00	120,00	8,00		x									HW..... 0950-06-100
95,00	120,00	12,00	x	x	x								HW..... 0950-07-100
95,00	120,00	13,00	x			x							HW..... 0950-08-100
95,00	120,00	15,00			x								HW..... 0950-09-100
95,00	125,00	10,00		x									HW..... 0950-10-100
95,00	125,00	12,00	x	x		x							HW..... 0950-11-100
95,00	130,00	13,00		x									HW..... 0950-12-100
95,00	133,00	14,00			x								HW..... 0950-13-100
95,25	127,00	11,00			x								HW..... 0953-01-100
96,00	112,00	10,00	x										HW..... 0960-01-100
98,00	120,00	12,00			x								HW..... 0980-01-100
98,00	125,00	10,00	x										HW..... 0980-02-100
98,00	125,00	13,00			x								HW..... 0980-03-100
98,40	125,00	13,00			x								HW..... 0984-01-100
100,00	115,00	9,00		x									HW..... 1000-01-100
100,00	120,00	10,00					x						HW..... 1000-02-100
100,00	120,00	12,00	x	x	x						x		HW..... 1000-03-100
100,00	120,00	13,00	x										HW..... 1000-04-100
100,00	120,00	14,00									x		HW..... 1000-05-100
100,00	125,00	12,00	x										HW..... 1000-06-100
100,00	125,00	13,00				x							HW..... 1000-07-100
100,00	130,00	12,00	x	x							x		HW..... 1000-08-100
100,00	130,00	13,00	x		x						x		HW..... 1000-09-100
100,00	130,00	14,00	x										HW..... 1000-10-100
100,00	136,53	12,70			x								HW..... 1000-11-100
100,00	140,00	13,00	x										HW..... 1000-12-100
100,00	150,00	13,00		x									HW..... 1000-13-100
100,00	160,00	12,00	x										HW..... 1000-14-100
100,00	160,00	15,00			x								HW..... 1000-15-100
100,00	180,00	13,00	x										HW..... 1000-16-100
101,60	127,00	12,70			x								HW..... 1016-01-100
101,60	127,10	12,70				x							HW..... 1016-02-100
101,60	136,68	11,13			x								HW..... 1016-03-100
101,60	139,70	12,70				x							HW..... 1016-04-100
101,60	139,70	14,29			x								HW..... 1016-05-100
101,60	146,05	14,28			x								HW..... 1016-06-100
102,00	115,00	10,00		x									HW..... 1020-01-100
102,00	125,00	13,00			x								HW..... 1020-02-100
102,00	130,00	13,00			x								HW..... 1020-03-100
104,00	130,00	10,00	x										HW..... 1040-01-100
105,00	125,00	13,00	x	x									HW..... 1050-01-100
105,00	130,00	12,00	x	x									HW..... 1050-02-100
105,00	130,00	13,00		x	x								HW..... 1050-03-100
105,00	130,00	15,00	x		x								HW..... 1050-04-100
105,00	135,00	15,00		x									HW..... 1050-05-100
105,00	140,00	12,00	x						x				HW..... 1050-06-100
105,00	150,00	15,00	x										HW..... 1050-07-100
105,00	150,00	15,00			x								HW..... 1050-08-100
105,00	160,00	12,00	x										HW..... 1050-09-100
106,40	130,00	10,00			x								HW..... 1064-01-100
107,95	136,45	12,70	x										HW..... 1079-01-100

Ø d h11	Ø D H8	E +0,3											Teile-Nr.
			400	410	420	430	440	450	460	470	480	500	
108,00	130,00	13,00			x								HW..... 1080-01-100
108,00	133,40	13,00			x								HW..... 1080-02-100
108,00	140,00	13,00			x								HW..... 1080-03-100
110,00	130,00	8,00	x										HW.....1100-01-100
110,00	130,00	12,00	x	x	x				x				HW..... 1100-02-100
110,00	130,00	13,00	x										HW..... 1100-03-100
110,00	130,00	14,50	x										HW..... 1100-04-100
110,00	135,00	12,00	x										HW..... 1100-05-100
110,00	140,00	10,00	x										HW..... 1100-06-100
110,00	140,00	12,00	x	x	x								HW..... 1100-07-100
110,00	140,00	13,00	x										HW..... 1100-08-100
110,00	140,00	13,00			x	x							HW..... 1100-09-100
110,00	140,00	15,00			x								HW..... 1100-10-100
110,00	150,00	13,00			x								HW..... 1100-11-100
110,00	150,00	15,00			x								HW..... 1100-12-100
110,00	152,00	15,00			x								HW..... 1100-13-100
112,00	140,00	13,00			x								HW..... 1120-01-100
112,00	200,00	10,00			x								HW..... 1120-02-100
113,00	140,00	13,00			x								HW..... 1130-01-100
114,30	139,70	12,70			x								HW..... 1143-01-100
115,00	140,00	10,00	x										HW..... 1150-01-100
115,00	140,00	12,00	x	x									HW..... 1150-02-100
115,00	140,00	13,00	x	x	x								HW..... 1150-03-100
115,00	145,00	16,00				x							HW..... 1150-04-100
115,00	150,00	12,00	x	x									HW..... 1150-05-100
115,00	150,00	13,00			x								HW..... 1150-06-100
115,00	150,00	16,00			x								HW..... 1150-07-100
118,00	150,00	12,00				x							HW..... 1180-01-100
118,00	150,00	15,00									x		HW..... 1180-02-100
119,00	140,00	15,00			x								HW..... 1190-01-100
120,00	140,00	10,00			x								HW..... 1200-01-100
120,00	140,00	13,00	x		x	x			x				HW..... 1200-02-100
120,00	150,00	10/12		x									HW..... 1200-03-100
120,00	150,00	10,00	x										HW..... 1200-04-100
120,00	150,00	12,00	x	x					x				HW..... 1200-05-100
120,00	150,00	13,00	x		x								HW..... 1200-06-100
120,00	150,00	15,00		x	x				x				HW..... 1200-07-100
120,00	152,00	16,00			x								HW..... 1200-08-100
120,00	155,00	12,00	x										HW..... 1200-09-100
120,00	155,00	16,00				x							HW..... 1200-10-100
120,00	160,00	12,00	x										HW..... 1200-11-100
120,00	160,00	13,00	x		x								HW..... 1200-12-100
120,00	160,00	15,00	x										HW..... 1200-13-100
120,00	200,00	15,00	x										HW..... 1200-14-100
122,00	150,00	12,00	x										HW..... 1220-01-100
122,00	150,00	15,00			x								HW..... 1220-02-100
124,00	150,00	15,00			x								HW..... 1240-01-100
125,00	140,00	10,00	x										HW..... 1250-01-100
125,00	143,00	13,00		x									HW..... 1250-02-100
125,00	150,00	10,00				x							HW..... 1250-03-100
125,00	150,00	12,00	x	x	x								HW..... 1250-04-100
125,00	150,00	13,00			x								HW..... 1250-05-100
125,00	155,00	12,00	x	x									HW..... 1250-06-100
125,00	160,00	12,00	x										HW..... 1250-07-100
125,00	160,00	15,00		x									HW..... 1250-08-100
125,00	162,00	12,00				x							HW..... 1250-09-100
125,00	162,00	15,00			x								HW..... 1250-10-100
126,00	158,00	10,00	x										HW..... 1260-01-100
127,00	152,40	12,70	x		x								HW..... 1270-01-100
128,00	146,00	13,50		x									HW..... 1280-01-100











Ø d h11	Ø D H8	E +0,3											Teile-Nr.
			400	410	420	430	440	450	460	470	480	500	
128,00	150,00	13,00	x										HW..... 1280-02-100
128,00	150,00	15,00			x								HW..... 1280-03-100
128,00	158,00	20,00	x										HW..... 1280-04-100
128,00	160,00	13,00	x										HW.....1280-05-100
130,00	150,00	10,00	x										HW..... 1300-01-100
130,00	150,00	12,00		x									HW..... 1300-02-100
130,00	150,00	14,00			x								HW..... 1300-03-100
130,00	150,00	15,00		x									HW..... 1300-04-100
130,00	155,00	12,00			x								HW..... 1300-05-100
130,00	160,00	12,00	x	x					x				HW..... 1300-06-100
130,00	160,00	13,00	x		x								HW..... 1300-07-100
130,00	160,00	14,00		x									HW..... 1300-08-100
130,00	160,00	15,00	x	x	x	x							HW..... 1300-09-100
130,00	170,00	12,00	x	x									HW..... 1300-10-100
130,00	170,00	13,00	x										HW..... 1300-11-100
130,00	170,00	15,00			x								HW..... 1300-12-100
130,00	170,00	16,00			x								HW..... 1300-13-100
132,50	155,60	13,00	x										HW..... 1325-01-100
133,30	158,70	12,70	x										HW..... 1333-01-100
134,50	155,50	9,52	x										HW..... 1345-01-100
135,00	160,00	12,00	x										HW..... 1350-01-100
135,00	160,00	13,00			x								HW..... 1350-02-100
135,00	160,00	15,00	x	x									HW..... 1350-03-100
135,00	170,00	12,00	x										HW..... 1350-04-100
135,00	170,00	15,00			x								HW..... 1350-05-100
135,00	180,00	15,00	x										HW..... 1350-06-100
138,00	160,00	15,00	x		x								HW..... 1350-07-100
139,70	165,10	12,70			x	x							HW..... 1397-01-100
139,70	171,60	15,87	x										HW..... 1397-02-100
139,70	174,60	14,28			x								HW..... 1397-03-100
140,00	160,00	12,00		x									HW..... 1400-01-100
140,00	160,00	13,00				x							HW..... 1400-02-100
140,00	165,00	12,00	x		x								HW..... 1400-03-100
140,00	165,00	12,50			x								HW..... 1400-04-100
140,00	165,00	15,00	x	x									HW..... 1400-05-100
140,00	170,00	8,00	x	x									HW..... 1400-06-100
140,00	170,00	12,00	x	x	x	x							HW..... 1400-07-100
140,00	170,00	14,00		x									HW..... 1400-08-100
140,00	170,00	15,00	x	x					x				HW..... 1400-09-100
140,00	180,00	12,00	x	x									HW..... 1400-10-100
140,00	180,00	13,00	x										HW..... 1400-11-100
140,00	180,00	15,00	x										HW..... 1400-12-100
140,00	190,00	15,00			x								HW..... 1400-13-100
143,00	170,00	10,00			x								HW..... 1430-01-100
144,00	160,00	12,00	x										HW..... 1440-01-100
144,80	175,00	12,00			x								HW..... 1448-01-100
145,00	165,00	15,00			x								HW..... 1450-01-100
145,00	167,00	13,00		x									HW..... 1450-02-100
145,00	170,00	10,00			x								HW..... 1450-03-100
145,00	170,00	13,00			x								HW..... 1450-04-100
145,00	170,00	15,00	x	x									HW..... 1450-05-100
145,00	180,00	12,00	x										HW..... 1450-06-100
145,00	180,00	13,00	x										HW..... 1450-07-100
145,00	180,00	14,00	x										HW..... 1450-08-100
145,00	180,00	15,00	x		x	x							HW..... 1450-09-100
146,00	163,00	7,00	x										HW..... 1460-01-100
146,00	170,00	15,00			x								HW..... 1460-02-100
148,00	170,00	14,50	x										HW..... 1480-01-100
149,00	170,00	14,50				x							HW..... 1480-02-100
149,00	180,00	15,00			x								HW..... 1490-01-100











Ø d h11	Ø D H8	E +0,3											Teile-Nr.
			400	410	420	430	440	450	460	470	480	500	
150,00	168,00	12,00	x										HW..... 1500-01-100
150,00	170,00	12,00	x										HW..... 1500-02-100
150,00	170,00	15,00			x								HW..... 1500-03-100
150,00	178,00	12,00		x									HW..... 1500-04-100
150,00	180,00	8/8,5							x				HW..... 1500-05-100
150,00	180,00	12,00	x										HW..... 1500-06-100
150,00	180,00	13,00	x	x									HW..... 1500-07-100
150,00	180,00	14,00	x										HW..... 1500-08-100
150,00	180,00	15,00	x	x	x	x							HW..... 1500-09-100
150,00	180,00	20,00		x									HW..... 1500-10-100
150,00	195,00	15,00			x								HW..... 1500-11-100
150,81	178,05	12,70	x										HW..... 1508-01-100
152,00	190,00	15,00			x								HW..... 1520-01-100
152,00	195,00	15,00			x								HW..... 1520-02-100
152,40	182,56	19,05			x								HW..... 1524-01-100
152,40	187,32	19,00		x									HW..... 1524-02-100
152,40	190,70	15,00			x								HW..... 1524-03-100
155,00	175,00	12,00	x										HW..... 1550-01-100
155,00	180,00	15,00			x								HW..... 1550-02-100
155,00	185,00	15,00		x									HW..... 1550-03-100
155,00	193,90	15,50			x								HW..... 1550-04-100
155,00	200,00	15,00			x								HW..... 1550-05-100
157,00	190,50	16,00			x								HW..... 1570-01-100
158,00	180,00	13,00	x										HW..... 1580-01-100
158,80	190,00	12,00			x								HW..... 1588-01-100
159,00	185,00	16,00			x								HW..... 1590-01-100
160,00	180,00	10,00		x									HW..... 1600-01-100
160,00	180,00	12,00		x									HW..... 1600-02-100
160,00	180,00	15,00			x								HW..... 1600-03-100
160,00	185,00	10,00	x										HW..... 1600-04-100
160,00	190,00	8,00							x				HW..... 1600-05-100
160,00	190,00	13,00	x	x	x								HW..... 1600-06-100
160,00	190,00	15,00	x	x									HW..... 1600-07-100
160,00	190,00	15,00			x	x							HW..... 1600-08-100
160,00	200,00	12,00	x	x									HW..... 1600-09-100
160,00	200,00	14,00			x								HW..... 1600-10-100
162,00	190,00	10,00			x								HW..... 1620-01-100
162,00	190,00	12,00	x										HW..... 1620-02-100
165,00	190,00	8,00		x									HW..... 1650-01-100
165,00	190,00	13,00	x										HW..... 1650-02-100
165,00	190,00	15,00				x							HW..... 1650-03-100
165,00	200,00	15,00	x	x									HW..... 1650-04-100
165,10	190,50	14,29			x								HW..... 1651-01-100
165,10	234,95	19,05				x							HW..... 1651-02-100
135,20	203,30	19,05	x										HW..... 1652-01-100
168,00	200,00	12,00			x								HW..... 1680-01-100
168,00	200,00	15,00	x										HW..... 1680-02-100
169,00	190,00	10,00			x								HW..... 1690-01-100
170,00	190,00	15,00	x	x	x								HW..... 1700-01-100
170,00	200,00	12,00	x										HW..... 1700-02-100
170,00	200,00	13,00			x								HW..... 1700-03-100
170,00	200,00	15,00	x	x									HW..... 1700-04-100
170,00	200,00	16,00	x			x							HW..... 1700-05-100
170,00	225,00	16,00			x								HW..... 1700-06-100
170,00	245,00	16,00			x								HW..... 1700-07-100
171,40	209,50	15,80			x								HW..... 1714-01-100
175,00	200,00	10,00	x										HW..... 1750-01-100
175,00	200,00	15,00	x	x	x								HW..... 1750-02-100
175,00	200,00	16,00	x										HW..... 1750-03-100
175,00	210,00	14,00	x										HW..... 1750-04-100











Ø d h11	Ø D H8	E +0,3											Teile-Nr.
			400	410	420	430	440	450	460	470	480	500	
175,00	210,00	15,00			x	x							HW..... 1750-05-100
177,80	203,20	15,88			x								HW..... 1778-01-100
177,80	222,25	19,05			x								HW..... 1778-02-100
178,00	200,00	12,00			x								HW..... 1780-01-100
180,00	200,00	13,00	x										HW..... 1800-01-100
180,00	200,00	15,00	x		x								HW..... 1800-02-100
180,00	200,00	16,00		x									HW..... 1800-03-100
180,00	210,00	15,00	x	x	x								HW..... 1800-04-100
180,00	215,00	15,00	x	x	x	x							HW..... 1800-05-100
180,00	215,00	16,00	x	x									HW..... 1800-06-100
180,00	220,00	15,00	x			x							HW..... 1800-07-100
184,15	222,25	14,50	x										HW..... 1842-01-100
185,00	210,00	13,00	x	x	x								HW..... 1850-01-100
185,00	210,00	15,00	x										HW..... 1850-02-100
185,00	215,00	15,00	x		x								HW..... 1850-03-100
185,00	215,00	16,00	x										HW..... 1850-04-100
185,00	220,00	15,00	x										HW..... 1850-05-100
185,00	230,00	16,00			x								HW..... 1850-06-100
186,00	215,90	12,00			x								HW..... 1860-01-100
186,00	216,00	12,00			x								HW..... 1860-02-100
188,00	215,00	16,00			x								HW..... 1880-01-100
190,00	215,00	15,00		x	x								HW..... 1900-01-100
190,00	215,00	16,00	x	x	x								HW..... 1900-02-100
190,00	220,00	12,00			x	x							HW..... 1900-03-100
190,00	220,00	15,00	x	x	x								HW..... 1900-04-100
190,00	220,00	16,00	x		x								HW..... 1900-05-100
190,00	225,00	16,00	x	x									HW..... 1900-06-100
190,00	230,00	15,00	x			x							HW..... 1900-07-100
190,00	230,00	16,00	x	x									HW..... 1900-08-100
190,50	215,90	15,75			x								HW..... 1905-01-100
190,50	222,25	15,00			x								HW..... 1905-02-100
190,50	228,60	19,05			x								HW..... 1905-03-100
192,00	210,00	10,00	x										HW..... 1920-01-100
193,70	219,10	12,70			x								HW..... 1937-01-100
194,00	222,00	12,00			x								HW..... 1940-01-100
195,00	215,00	15,00		x									HW..... 1950-01-100
195,00	220,00	16,00			x								HW..... 1950-02-100
195,00	230,00	15,00			x								HW..... 1950-03-100
195,00	230,00	16,00			x								HW..... 1950-04-100
196,85	241,30	19,05			x								HW..... 1971-01-100
200,00	225,00	12,50			x								HW..... 2000-01-100
200,00	225,00	15,00	x										HW..... 2000-02-100
200,00	230,00	13,00	x	x									HW..... 2000-03-100
200,00	230,00	15,00	x	x	x	x							HW..... 2000-04-100
200,00	230,00	16,00			x								HW..... 2000-05-100
200,00	230,00	18,00				x							HW..... 2000-06-100
200,00	235,00	15,00	x										HW..... 2000-07-100
200,00	240,00	15,00	x		x		x						HW..... 2000-08-100
200,00	240,00	20,00				x							HW..... 2000-09-100
200,00	250,00	15,00	x		x								HW..... 2000-10-100
200,00	250,00	16,00	x										HW..... 2000-11-100
203,00	230,00	12,00				x							HW..... 2030-01-100
203,00	230,00	14,00			x								HW..... 2030-02-100
203,20	241,30	19,05			x								HW..... 2032-01-100
203,20	254,00	15,87				x							HW..... 2032-02-100
205,00	230,00	15,00			x								HW..... 2050-01-100
205,00	230,00	16,00	x		x								HW..... 2050-02-100
205,00	250,00	16,00			x								HW..... 2050-03-100
207,00	240,00	16,00		x									HW..... 2070-01-100
209,60	235,00	12,70			x								HW..... 2096-01-100

Ø d h11	Ø D H8	E +0,3											Teile-Nr.
			400	410	420	430	440	450	460	470	480	500	
210,00	230,00	16,00			x								HW..... 2100-01-100
210,00	235,00	12,00			x								HW..... 2100-02-100
210,00	240,00	13,00	x										HW..... 2100-03-100
210,00	240,00	15,00	x	x									HW..... 2100-04-100
210,00	240,00	16,00			x								HW..... 2100-05-100
210,00	250,00	15,00	x		x	x							HW..... 2100-06-100
210,00	250,00	16,00			x								HW..... 2100-07-100
210,00	250,00	20,00				x							HW..... 2100-08-100
210,00	260,00	15,00	x		x								HW..... 2100-09-100
210,00	260,00	25,00			x								HW..... 2100-10-100
210,00	290,00	20,00	x	x									HW..... 2100-11-100
214,00	241,50	15,00			x								HW..... 2140-01-100
215,00	240,00	12,00	x		x								HW..... 2150-01-100
215,00	245,00	16,00			x								HW..... 2150-02-100
215,00	248,00	15,00	x										HW..... 2150-03-100
215,00	250,00	15,00			x								HW..... 2150-04-100
215,00	250,00	16,00			x								HW..... 2150-05-100
215,90	241,30	12,70			x								HW..... 2159-01-100
215,90	247,65	19,05			x								HW..... 2159-02-100
215,90	254,10	14,28		x									HW..... 2159-03-100
215,90	254,10	19,05		x									HW..... 2159-04-100
219,10	244,50	12,70			x								HW..... 2191-01-100
220,00	250,00	12,00	x										HW..... 2200-01-100
220,00	250,00	15,00	x	x	x	x							HW..... 2200-02-100
220,00	250,00	16,00	x			x					x		HW..... 2200-03-100
220,00	250,00	18,00				x							HW..... 2200-03-100
220,00	255,00	16,00	x										HW..... 2200-04-100
220,00	255,00	18,00	x										HW..... 2200-05-100
220,00	260,00	15,00	x										HW..... 2200-06-100
220,00	260,00	16,00	x										HW..... 2200-07-100
220,00	260,00	18,00			x								HW..... 2200-08-100
220,00	260,00	22,00			x	x							HW..... 2200-09-100
220,00	270,00	15,00			x								HW..... 2200-10-100
220,00	280,00	20,00	x										HW..... 2200-11-100
225,00	250,00	12,50			x								HW..... 2250-01-100
225,00	250,00	16,00			x								HW..... 2250-02-100
228,60	254,00	19,05			x								HW..... 2286-01-100
229,00	255,00	15,00			x								HW..... 2290-01-100
230,00	260,00	12,50	x										HW..... 2300-01-100
230,00	260,00	15,00	x	x	x								HW..... 2300-02-100
230,00	270,00	15,00	x		x								HW..... 2300-03-100
230,00	270,00	16,00			x	x							HW..... 2300-04-100
230,00	280,00	15,00	x										HW..... 2300-05-100
230,00	280,00	16,00	x		x								HW..... 2300-06-100
230,00	285,00	23,00			x								HW..... 2300-07-100
235,00	265,00	15,00	x										HW..... 2350-01-100
235,00	270,00	15,00			x								HW..... 2350-02-100
235,00	270,00	16,00			x								HW..... 2350-03-100
240,00	270,00	15,00	x	x	x	x							HW..... 2400-01-100
240,00	270,00	16,00			x								HW..... 2400-02-100
240,00	270,00	18,50							x				HW..... 2400-03-100
240,00	275,00	16,00	x										HW..... 2400-04-100
240,00	280,00	15,00	x										HW..... 2400-05-100
240,00	280,00	16,00	x		x								HW..... 2400-06-100
240,00	280,00	18,50							x				HW..... 2400-07-100
240,00	280,00	20,00				x							HW..... 2400-08-100
240,00	290,00	16,00			x								HW..... 2400-09-100
241,30	292,30	25,40	x										HW..... 2413-01-100
241,30	317,70	20,60			x								HW..... 2413-02-100
245,00	270,00	16,00			x								HW..... 2450-01-100

Ø d h11	Ø D H8	E +0,3											Teile-Nr.
			400	410	420	430	440	450	460	470	480	500	
245,00	285,00	16,50			x								HW..... 2450-02-100
250,00	280,00	15,00	x	x	x	x							HW..... 2500-01-100
250,00	280,00	16,00			x								HW..... 2500-02-100
250,00	285,00	18,00		x									HW..... 2500-03-100
250,00	290,00	15,00			x								HW..... 2500-04-100
250,00	290,00	16,00	x		x								HW..... 2500-05-100
250,00	310,00	25,00			x								HW..... 2500-06-100
254,00	279,40	12,70			x								HW..... 2540-01-100
254,00	292,10	19,05			x								HW..... 2540-02-100
254,00	304,80	15,88			x								HW..... 2540-03-100
255,00	290,00	16,00			x								HW..... 2550-01-100
259,00	300,00	20,00									x		HW..... 2600-01-100
260,00	280,00	16,00			x								HW..... 2600-02-100
260,00	290,00	15,00	x										HW..... 2600-03-100
260,00	290,00	16,00	x		x	x							HW..... 2600-04-100
260,00	290,00	20,00			x								HW..... 2600-05-100
260,00	300,00	16,00			x								HW..... 2600-06-100
260,00	300,00	20,00	x		x	x							HW..... 2600-07-100
260,00	310,00	16,00			x								HW..... 2600-08-100
260,00	320,00	25,00			x	x							HW..... 2600-09-100
265,00	290,00	16,00	x		x								HW..... 2650-01-100
265,00	300,00	16,00			x								HW..... 2650-02-100
265,00	310,00	16,00			x								HW..... 2650-03-100
266,70	304,80	19,05			x	x							HW..... 2667-01-100
266,70	317,50	15,88			x								HW..... 2667-02-100
267,00	300,00	20,00			x								HW..... 2670-01-100
267,00	318,00	19,00		x									HW..... 2670-02-100
268,00	300,00	16,00			x								HW..... 2680-01-100
270,00	300,00	15,00	x										HW..... 2700-01-100
270,00	310,00	16,00	x		x								HW..... 2700-02-100
270,00	330,00	25,00			x								HW..... 2700-03-100
272,00	310,00	16,00			x								HW..... 2720-01-100
275,00	310,00	16,00			x								HW..... 2750-01-100
275,00	320,00	15,00	x										HW..... 2750-02-100
279,40	304,80	12,70			x								HW..... 2794-01-100
279,40	304,80	16,66	x										HW..... 2794-02-100
279,40	330,00	19,05				x							HW..... 2794-03-100
280,00	210,00	15,00	x										HW..... 2800-01-100
280,00	310,00	16,00	x	x	x	x							HW..... 2800-02-100
280,00	315,00	15,00		x									HW..... 2800-02-100
280,00	315,00	16,00	x										HW..... 2800-03-100
280,00	316,00	18,00			x								HW..... 2800-04-100
280,00	320,00	15,00	x										HW..... 2800-05-100
280,00	320,00	16,00	x		x	x							HW..... 2800-06-100
280,00	320,00	20,00	x	x	x	x							HW..... 2800-07-100
280,00	324,00	25,00			x								HW..... 2800-08-100
280,00	380,00	20,00			x								HW..... 2800-09-100
280,00	400,00	15,00			x								HW..... 2800-10-100
285,00	310,00	16,00			x								HW..... 2850-01-100
285,00	320,00	16,00			x								HW..... 2850-02-100
285,00	325,00	15,00			x								HW..... 2850-03-100
285,00	325,00	16,00			x								HW..... 2850-04-100
285,00	330,00	20,00			x								HW..... 2850-05-100
285,75	336,55	23,81	x										HW..... 2857-01-100
290,00	320,00	15,00	x										HW..... 2900-01-100
290,00	321,00	19,00	x										HW..... 2900-02-100
290,00	330,00	15,00			x								HW..... 2900-03-100
290,00	330,00	16,00			x								HW..... 2900-04-100
290,00	330,00	18,00	x	x	x								HW..... 2900-05-100
290,00	334,00	20,00			x								HW..... 2900-06-100

Ø d h11	Ø D H8	E +0,3											Teile-Nr.
			400	410	420	430	440	450	460	470	480	500	
290,00	350,00	25,00			x								HW..... 2900-07-100
295,00	335,00	16,00			x								HW..... 2950-01-100
295,00	335,00	18,00			x								HW..... 2950-02-100
300,00	332,00	16,00	x		x	x							HW..... 3000-01-100
300,00	335,00	18,00			x								HW..... 3000-02-100
300,00	340,00	16,00	x		x								HW..... 3000-03-100
300,00	340,00	18,00	x	x	x								HW..... 3000-04-100
300,00	340,00	20,00	x	x	x	x							HW..... 3000-05-100
300,00	342,00	16,00			x								HW..... 3000-06-100
300,00	344,00	20,50			x								HW..... 3000-07-100
300,00	350,00	18,00			x								HW..... 3000-08-100
300,00	350,00	19,00			x								HW..... 3000-09-100
300,00	350,00	20,00			x								HW..... 3000-10-100
300,00	360,00	18,00			x								HW..... 3000-11-100
300,00	400,00	18,00			x								HW..... 3000-12-100
300,00	420,00	20,00			x								HW..... 3000-13-100
304,80	330,20	12,70			x								HW..... 3048-01-100
304,80	355,60	25,40			x								HW..... 3048-02-100
305,00	340,00	18,00			x								HW..... 3050-01-100
305,00	345,00	20,00			x								HW..... 3050-02-100
310,00	340,00	15,00		x									HW..... 3100-01-100
310,00	350,00	18,00			x								HW..... 3100-02-100
310,00	350,00	20,00	x										HW..... 3100-03-100
310,00	370,00	28,00			x								HW..... 3100-04-100
315,00	355,00	16,50			x								HW..... 3150-01-100
315,00	355,00	18,00			x								HW..... 3150-02-100
315,00	365,00	20,00			x								HW..... 3150-03-100
316,00	360,00	20,00	x										HW..... 3160-01-100
317,10	368,30	18,00		x									HW..... 3171-01-100
317,50	349,25	19,50			x								HW..... 3175-01-100
320,00	350,00	16,00			x								HW..... 3200-01-100
320,00	350,00	18,00			x								HW..... 3200-02-100
320,00	360,00	15,00			x								HW..... 3200-03-100
320,00	360,00	18,00	x		x								HW..... 3200-04-100
320,00	360,00	20,00	x		x	x							HW..... 3200-05-100
320,00	360,00	25,00			x								HW..... 3200-06-100
320,00	360,00	32,00			x								HW..... 3200-07-100
320,00	363,00	20,00	x										HW..... 3200-08-100
320,00	380,00	20,00			x								HW..... 3200-09-100
320,00	380,00	25,00			x								HW..... 3200-10-100
325,00	360,00	16,00			x								HW..... 3250-01-100
325,00	365,00	16,00			x								HW..... 3250-02-100
325,00	365,00	20,00									x		HW..... 3250-03-100
330,00	360,00	15,00			x								HW..... 3300-01-100
330,00	370,00	18,00	x		x	x							HW..... 3300-02-100
330,00	370,00	20,00	x		x								HW..... 3300-03-100
330,00	380,00	20,00			x								HW..... 3300-04-100
330,00	385,00	18,00			x								HW..... 3300-05-100
330,20	381,00	23,79			x								HW..... 3302-01-100
340,00	370,00	20,00	x										HW..... 3400-01-100
340,00	372,00	16,00	x		x								HW..... 3400-02-100
340,00	380,00	15,00	x										HW..... 3400-03-100
340,00	380,00	16,00			x								HW..... 3400-04-100
340,00	380,00	18,00	x		x								HW..... 3400-05-100
340,00	380,00	20,00	x	x	x								HW..... 3400-06-100
340,00	390,00	20,00			x								HW..... 3400-07-100
340,00	400,00	25,00			x								HW..... 3400-08-100
342,90	368,30	12,70				x							HW..... 3429-01-100
350,00	380,00	15,00	x										HW..... 3500-01-100
350,00	380,00	16,00			x								HW..... 3500-02-100

Ø d h11	Ø D H8	E +0,3											Teile-Nr.
			400	410	420	430	440	450	460	470	480	500	
350,00	390,00	18,00	x		x	x							HW..... 3500-03-100
350,00	390,00	20,00				x							HW..... 3500-04-100
355,00	395,00	32,00			x								HW..... 3550-01-100
355,00	405,00	15,00			x								HW..... 3550-02-100
360,00	390,00	15,00		x									HW..... 3600-01-100
360,00	390,00	20,00			x								HW..... 3600-02-100
360,00	392,00	20,00			x	x							HW..... 3600-03-100
360,00	400,00	18,00			x								HW..... 3600-04-100
360,00	400,00	20,00	x		x	x							HW..... 3600-05-100
360,00	404,00	20,00	x										HW..... 3600-06-100
360,00	425,00	20,00			x								HW..... 3600-07-100
365,00	395,00	15,00			x								HW..... 3650-01-100
365,00	405,00	18,00			x								HW..... 3650-02-100
365,00	410,00	20,00			x								HW..... 3650-03-100
368,30	406,40	17,45	x										HW..... 3683-01-100
370,00	400,00	10,00			x								HW..... 3700-01-100
370,00	410,00	15,00	x		x								HW..... 3700-02-100
370,00	410,00	20,00			x	x							HW..... 3700-03-100
370,00	415,00	15,00			x								HW..... 3700-04-100
375,00	420,00	18,00			x								HW..... 3750-01-100
375,00	430,00	18,00			x								HW..... 3750-02-100
380,00	420,00	18,00			x								HW..... 3800-01-100
380,00	420,00	20,00	x	x	x								HW..... 3800-02-100
380,00	430,00	19,00			x								HW..... 3800-03-100
381,00	431,80	25,40			x								HW..... 3810-01-100
381,00	438,15	22,22			x								HW..... 3810-02-100
385,00	430,00	25,00	x										HW..... 3850-01-100
390,00	425,00	18,00				x							HW..... 3900-01-100
390,00	430,00	16,00	x										HW..... 3900-02-100
390,00	430,00	18,00			x								HW..... 3900-03-100
390,00	430,00	20,00	x										HW..... 3900-04-100
390,00	435,00	18,00				x							HW..... 3900-05-100
390,00	440,00	25,00			x								HW..... 3900-06-100
393,70	444,50	20,57			x								HW..... 3937-01-100
394,00	420,00	16,00	x	x	x								HW..... 3940-01-100
395,00	430,00	15,00			x								HW..... 3950-01-100
395,00	430,00	18,00			x								HW..... 3950-02-100
400,00	430,00	26,00			x								HW..... 4000-01-100
400,00	438,50	17,00			x								HW..... 4000-02-100
400,00	440,00	15,00			x								HW..... 4000-03-100
400,00	440,00	18,00			x								HW..... 4000-04-100
400,00	440,00	20,00	x		x								HW..... 4000-05-100
400,00	450,00	18,00			x								HW..... 4000-06-100
400,00	450,00	20,00			x								HW..... 4000-07-100
400,00	450,00	25,00				x							HW..... 4000-08-100
400,00	451,00	17,45	x		x								HW..... 4000-09-100
400,00	470,00	20,00			x								HW..... 4000-10-100
400,00	500,00	25,00			x								HW..... 4000-11-100
404,00	438,00	19,05	x										HW..... 4040-01-100
410,00	454,00	20,50			x								HW..... 4100-01-100
410,00	460,00	15,00			x								HW..... 4100-02-100
410,00	460,00	22,00			x								HW..... 4100-03-100
420,00	460,00	15,00			x								HW..... 4200-01-100
420,00	460,00	16,00	x										HW..... 4200-02-100
420,00	460,00	18,00	x		x								HW..... 4200-03-100
420,00	460,00	20,00	x		x								HW..... 4200-04-100
420,00	470,00	20,00		x									HW..... 4200-05-100
420,00	480,00	15,00			x								HW..... 4200-06-100
425,00	475,00	22,00			x								HW..... 4250-01-100
425,00	480,00	15,00			x								HW..... 4250-02-100

Ø d h11	Ø D H8	E +0,3											Teile-Nr.
			400	410	420	430	440	450	460	470	480	500	
430,00	480,00	22,00			x								HW..... 4300-01-100
430,00	480,00	25,00			x								HW..... 4300-02-100
430,00	495,00	25,00			x								HW..... 4300-03-100
431,80	469,90	19,05				x							HW..... 4318-01-100
435,00	485,00	17,45	x										HW..... 4350-01-100
440,00	470,00	20,00			x								HW..... 4400-01-100
440,00	480,00	20,00	x	x	x								HW..... 4400-02-100
440,00	490,00	17,00			x								HW..... 4400-03-100
440,00	490,00	20,00			x								HW..... 4400-04-100
445,00	480,00	16,00		x	x								HW..... 4450-01-100
445,00	480,00	18,00			x								HW..... 4450-02-100
448,00	480,00	15,00			x								HW..... 4480-01-100
450,00	490,00	18,00			x								HW..... 4500-01-100
450,00	490,00	20,00			x								HW..... 4500-02-100
450,00	500,00	22,00	x										HW..... 4500-03-100
450,00	500,00	25,00			x								HW..... 4500-04-100
455,00	495,00	20,00			x								HW..... 4550-01-100
457,00	508,00	25,40			x								HW..... 4570-01-100
457,20	495,30	19,05			x								HW..... 4572-01-100
460,00	500,00	20,00	x		x								HW..... 4600-01-100
460,00	510,00	25,00			x								HW..... 4600-02-100
460,00	520,00	26,00			x								HW..... 4600-03-100
461,00	500,00	20,00			x								HW..... 4610-01-100
467,00	510,00	20,00			x								HW..... 4670-01-100
470,00	510,00	20,00			x								HW..... 4700-01-100
470,00	520,00	18,00			x								HW..... 4700-02-100
470,00	520,00	20,00			x								HW..... 4700-03-100
470,00	520,00	22,00			x								HW..... 4700-04-100
475,00	530,00	18,00			x								HW..... 4750-01-100
480,00	520,00	20,00	x	x	x	x							HW..... 4800-01-100
480,00	530,00	25,00	x										HW..... 4800-02-100
480,00	550,00	25,00			x								HW..... 4800-03-100
490,00	530,00	20,00			x								HW..... 4900-01-100
490,00	540,00	25,00	x										HW..... 4900-02-100
500,00	520,00	12,00			x								HW..... 5000-01-100
500,00	535,00	12,00			x								HW..... 5000-02-100
500,00	540,00	20,00	x	x	x								HW..... 5000-03-100
500,00	550,00	20,00			x								HW..... 5000-04-100
500,00	550,00	22,00	x		x								HW..... 5000-05-100
500,00	560,00	20,00			x								HW..... 5000-06-100
508,00	558,80	25,40	x		x								HW..... 5080-01-100
510,00	550,00	20,00			x								HW..... 5100-01-100
510,00	572,00	20,00			x								HW..... 5100-02-100
520,00	580,00	20,00			x								HW..... 5207-01-100
520,70	571,50	22,50			x								HW..... 5207-02-100
525,00	575,00	25,00	x										HW..... 5250-01-100
530,00	565,00	20,00			x								HW..... 5300-01-100
530,00	570,00	20,00			x								HW..... 5300-02-100
530,00	580,00	20,00			x								HW..... 5300-03-100
533,40	584,20	22,22			x								HW..... 5334-01-100
540,00	580,00	20,00			x								HW..... 5400-01-100
540,00	590,00	22,00			x								HW..... 5400-02-100
540,00	590,00	25,50			x								HW..... 5400-03-100
546,00	596,90	19,05			x								HW..... 5460-01-100
550,00	590,00	20,00			x								HW..... 5500-01-100
550,00	600,00	22,00			x								HW..... 5500-02-100
555,00	600,00	20,00			x								HW..... 5550-01-100
560,00	610,00	20,00	x		x								HW..... 5600-01-100
560,00	620,00	20,00			x								HW..... 5600-02-100
560,00	620,00	25,00			x								HW..... 5600-03-100



RADIALWELLENDICHTRING

HW 400 BIS HW 500

Ø d h11	Ø D H8	E +0,3											Teile-Nr.
			400	410	420	430	440	450	460	470	480	500	
565,00	630,00	20,00			x								HW..... 5650-01-100
570,00	620,00	22,00			x								HW..... 5700-01-100
570,00	630,00	25,00			x								HW..... 5700-02-100
580,00	615,00	20,00			x								HW..... 5800-01-100
580,00	630,00	20,00			x								HW..... 5800-02-100
580,00	636,00	25,00			x								HW..... 5800-03-100
580,00	640,00	25,00			x								HW..... 5800-04-100
580,00	640,00	30,00			x								HW..... 5800-05-100
590,50	628,60	15,87			x								HW..... 5905-01-100
595,00	635,00	20,00			x								HW..... 5950-01-100
600,00	640,00	20,00	x		x								HW..... 6000-01-100
600,00	640,00	22,00			x	x							HW..... 6000-02-100
600,00	650,00	25,00			x								HW..... 6000-03-100
609,60	660,40	22,23			x								HW..... 6096-01-100
610,00	650,00	20,00			x								HW..... 6100-01-100
610,00	660,00	20,00			x								HW..... 6100-02-100
620,00	660,00	20,00			x								HW..... 6200-01-100
620,00	670,00	25,00			x								HW..... 6200-02-100
620,00	680,00	25,00			x								HW..... 6200-03-100
628,00	655,00	20,00			x								HW..... 6280-01-100
630,00	670,00	20,00			x								HW..... 6300-01-100
630,00	680,00	20,00			x								HW..... 6300-02-100
630,00	690,00	30,00			x								HW..... 6300-03-100
630,00	700,00	20,00			x								HW..... 6300-04-100
632,00	672,00	20,00			x								HW..... 6320-01-100
640,00	680,00	20,00			x								HW..... 6400-01-100
640,00	690,00	25,00			x								HW..... 6400-02-100
645,00	677,00	16,00			x								HW..... 6450-01-100
650,00	690,00	18,00			x								HW..... 6500-01-100
650,00	690,00	20,00			x								HW..... 6500-02-100
650,00	700,00	20,00			x								HW..... 6500-03-100
650,00	710,00	25,00			x								HW..... 6500-04-100
660,00	700,00	18,00			x								HW..... 6600-01-100
660,00	704,00	20,50			x								HW..... 6600-02-100
670,00	710,00	20,00	x		x								HW..... 6700-01-100
670,00	730,00	25,00	x		x								HW..... 6700-02-100
695,00	740,00	20,00			x								HW..... 6950-01-100
700,00	740,00	20,00			x								HW..... 7000-01-100
710,00	760,00	20,00			x								HW..... 7100-01-100
740,00	780,00	20,00			x								HW..... 7400-01-100
750,00	790,00	23,00			x								HW..... 7500-01-100
750,00	800,00	25,00			x								HW..... 7500-02-100
790,00	830,00	23,00			x								HW..... 7900-01-100
840,00	880,00	20,00			x								HW..... 8400-01-100
850,90	914,40	22,20			x								HW..... 8509-01-100
860,00	900,00	20,00			x								HW..... 8600-01-100
950,00	1000,00	20,00			x								HW..... 9500-01-100

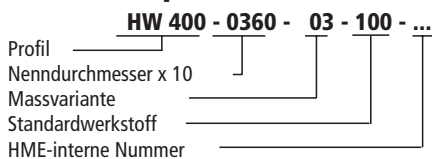
Bestellbeispiel:**Werkstoff-Schlüssel:****Profil-Übersicht**

HW400 - Form A
HW410 - Form AS
HW420 - Form C
HW430 - Form CS
HW440 - Form B
HW450 - Form BS
HW460 - Form P
HW470 - Form O
HW480 - Form DUO
HW500 - Form DINA

Werkstoff-Übersicht

100 - NBR
120 - FPM
180 - Silikon

Die genannten Einsatzgrenzen sind Richtwerte. Unter Berücksichtigung der jeweiligen Betriebsbedingungen können die Werte im einzelnen überschritten werden. Bei großer Einschaltdauer, stoßweisem Betrieb oder anderen erschwerenden Betriebsbedingungen empfiehlt es sich, diese Werte nicht gleichzeitig auszunutzen.

Wegen der Vielfalt in der praktischen Anwendung kann im Einzelfall keine Gewährleistung und Haftung für die Richtigkeit und Funktionsfähigkeit übernommen werden. Änderungen sind vorbehalten.

Ausgabe

01 05