

Double action piston seals of the HK 101 series have been specially manufactured for use in mounting areas as per DIN ISO 6547. Compact design allows sealing and sliding function in restricted space.

Careful choice of materials renders the product serviceable in extreme service conditions.

Special Features:

- Series specially meant for mounting as per DIN ISO 6547
- 5 part sealing set with single piece piston snap assembly possible
- sealing components from special anti-wear NBR
- Resistant to torsion through form locking combination of sliding-support and sealing ring (gasket)
- heavy duty slide rings with pressure relief grooves

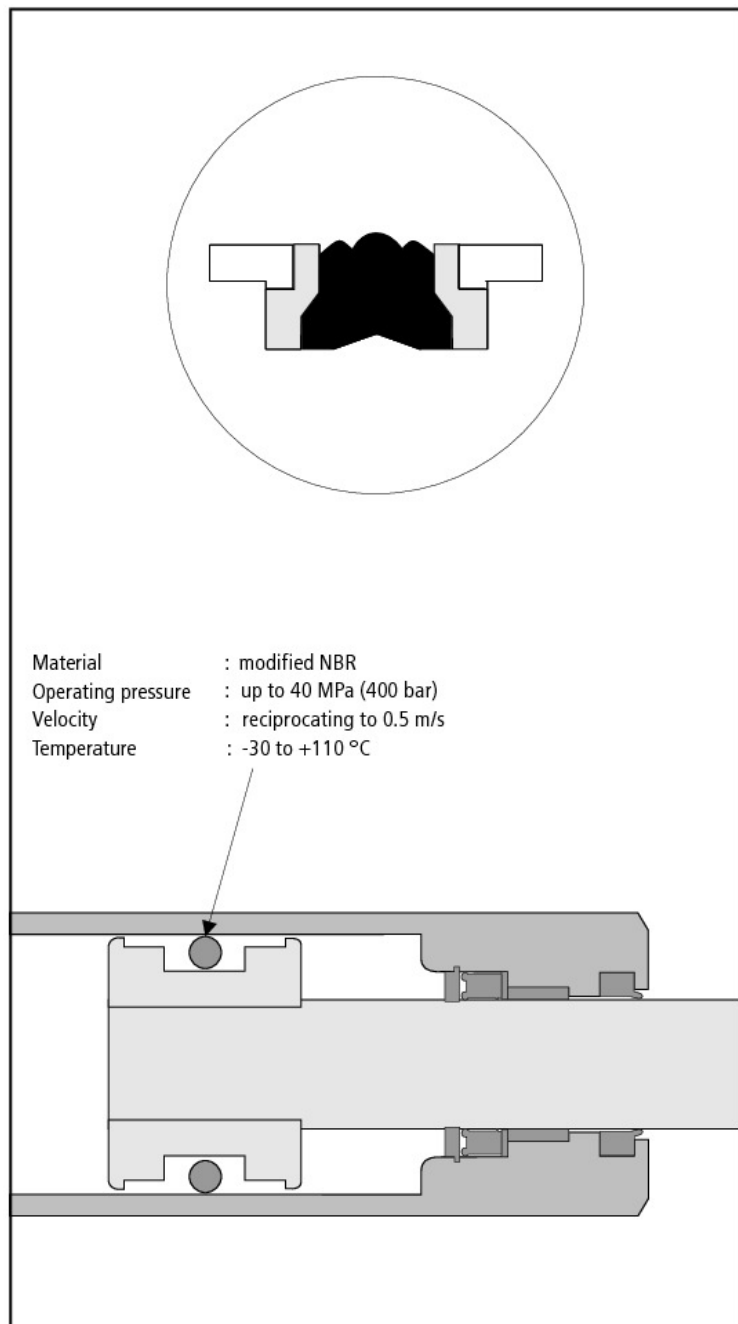

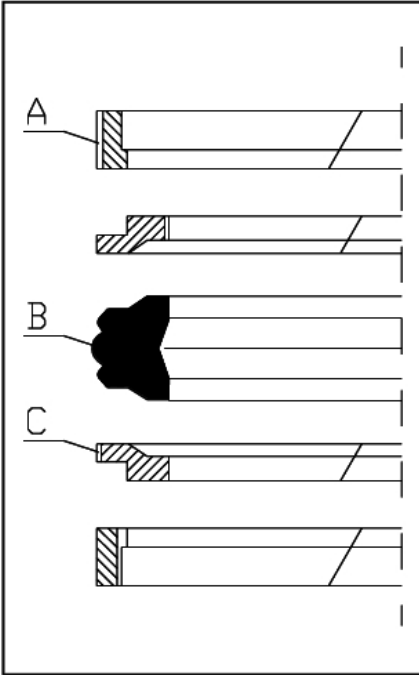

Angular Slide Rings - Part A

Material: filled Polyamide

Short insides of the split/partioned slide rings guarantee considerably simpler assembly on single piece pistons. The practical design facilitates optimal distribution of transverse forces/shear forces that come into play. Axial unloading grooves ensure a shorter response time of the seal in case of quick changes in load. Specially designed materials ensure high pressure stability, even in case of variable thermal conditions. Low finishing tolerances ensure better piston sliding and optimize the seal function.

Elastomeric Seal Components - Part B

Material: NBR

Sturdy sealing elements from highly wear-resistant NBR are proven to be superior due to low compression strain and high tensile strength. Out of the three sealing edges, the larger one in the middle serves as the primary seal, and the two smaller external lips serve as a pre-seal. The broad clamping area is taken up by static sealing of the groove base/root. Specially designed angular shoulders incorporated on both sides eliminate the possibility of turning of the sealing element in the event of shocks.

Thrust Ring - Part C (backup-up-ring)

Material: Polyester-Elastomer

Both thrust rings together produce the required form and force locking arrangements between sealing element and slide ring. Special material and close tolerances prevent split extrusion of the sliding elements.

Unloading grooves/relief grooves on the dynamic side eliminate pressure concentration even with quick load variations.

Double acting piston seals of the HK 105 series are specifically manufactured for the use in applications designed as per DIN ISO 6547. Universal range of applications ranging from low pressure applications to heavy hydraulic is an advantage.

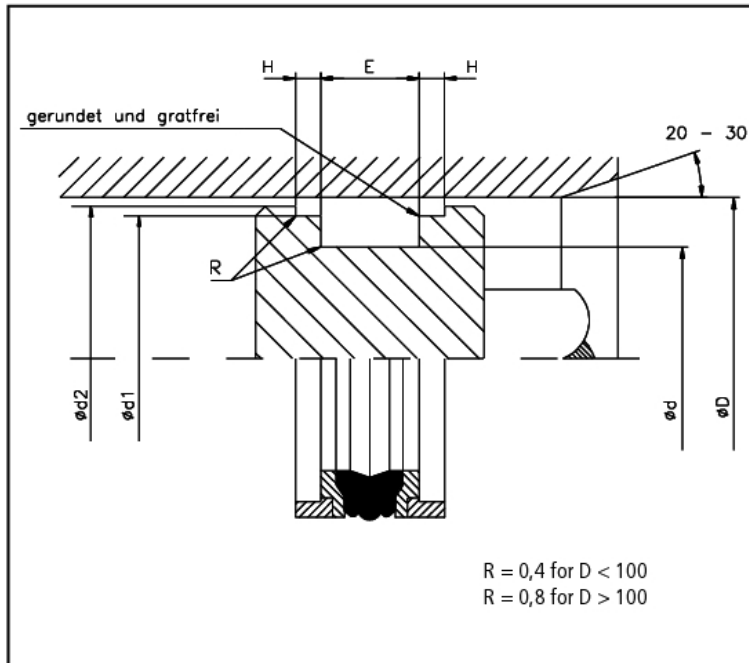

Limitations on Use

Maximum allowable operational pressure depending on the rubbing speed and temperature range of application as given below:

Vmax [m/s]	Application Temperature [°C]		
	-30 +60	-30 +80	-30 +110
0,50	250 bar	160 bar	100 bar
0,15	400 bar	250 bar	160 bar

Media for Use

Mineral oil based hydraulic oils, flame resistant pressure media and emulsions (HFA, HFB, HFC), Bio Oils.

Surface Finish

Surfaces	Rmax	Rz	Ra
Faces	2,5 µm	1,6 µm	0,4 µm
Groove root	10,0 µm	6,3 µm	1,6 µm
Groove flanks or sides	16,0 µm	10,0 µm	3,2 µm

Extensive range of inch measurement diagrams available on request.

D H9	d h9	E +0,35	H +0,1	d1 h9	d2 h11	Part N°.
25,00	15,00	12,50	4,00	22,00	24,00	HK101 0250-01-100
25,00	17,00	10,00	4,00	22,00	24,00	HK101 0250-02-100
32,00	22,00	12,50	4,00	29,00	31,00	HK101 0320-01-100
32,00	24,00	10,00	4,00	29,00	31,00	HK101 0320-02-100
40,00	30,00	12,50	4,00	37,00	39,00	HK101 0400-01-100
40,00	32,00	10,00	4,00	37,00	39,00	HK101 0400-02-100
50,00	35,00	20,00	5,00	46,00	48,50	HK101 0500-01-100
50,00	40,00	12,50	4,00	47,00	49,00	HK101 0500-02-100
63,00	48,00	20,00	5,00	59,00	61,50	HK101 0630-01-100
63,00	53,00	12,50	4,00	60,00	62,00	HK101 0630-02-100
80,00	60,00	25,00	6,30	75,00	78,00	HK101 0800-01-100
80,00	65,00	20,00	5,00	76,00	78,50	HK101 0800-02-100
100,00	80,00	25,00	6,30	95,00	98,00	HK101 1000-01-100
100,00	85,00	20,00	5,00	96,00	98,50	HK101 1000-02-100
125,00	100,00	32,00	10,00	119,00	123,00	HK101 1250-01-100
125,00	105,00	25,00	6,30	120,00	123,00	HK101 1250-02-100
140,00	115,00	32,00	10,00	134,00	138,00	HK101 1400-01-100
140,00	120,00	25,00	6,30	135,00	138,00	HK101 1400-02-100
160,00	135,00	32,00	10,00	154,00	158,00	HK101 1600-01-100
160,00	140,00	25,00	6,30	155,00	158,00	HK101 1600-02-100
180,00	150,00	36,00	12,50	172,00	177,00	HK101 1800-01-100
200,00	170,00	36,00	12,50	192,00	197,00	HK101 2000-01-100
250,00	220,00	36,00	12,50	242,00	247,00	HK101 2500-01-100
320,00	290,00	36,00	12,50	312,00	317,00	HK101 3200-01-100

All forms were not available at the time of printing. Please enquire in case of difficulty.

Example for ordering Piston Seal:

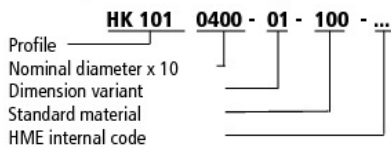

Material Key:

- 100 - NBR
- 120 - FPM

Issue

01	05
----	----

WARNING: Limits of application stated herein are standard values. They could be individually transgressed with due consideration to respective service conditions. In the event of a large duty cycle, pulsating operation and other complex operational conditions, simultaneous transgression of these values is not recommended. Due to a large variety of service conditions that may arise in course of actual use, the company does not take responsibility of or guarantee the functional accuracy of the individual components. Rights for changes are reserved.